

EXTREME SERIES **OWNER'S MANUAL**

Extreme 3500 ti

Extreme 5000 ti

Extreme 8000 ti

Extreme 3500 tiR

Extreme 5000 tiR

Extreme 8000 tiR

Extreme 5000 tiR FD

***Whisper* KOOL™**
The Coolest Thing In Wine Storage

We manufacture, test and certify 100% of our wine cooling units in the USA. By sourcing the best components and closely controlling our manufacturing processes, we can assure the highest-quality, lowest defect manufacturing rates in the industry.

Copyright © 2012. WhisperKOOL. All rights reserved.

WhisperKOOL copyrights this manual, the product design, and the design concepts, with all rights reserved. Your rights with regard to the hardware and manual are subject to the restrictions and limitations imposed by the copyright laws of the USA. Under copyright laws, this manual may not be copied, reproduced, translated, transmitted, or reduced to any printed or electronic medium or to any machine-readable form, for any purpose, in whole or in part, without the written consent of WhisperKOOL.

Every effort has been made to ensure that the information in this manual is accurate. WhisperKOOL is not responsible for printing or clerical errors.

WhisperKOOL reserves the right to make corrections or improvements to the information provided and to the related hardware at any time, without notice.

Vinothèque and WhisperKOOL are registered trademarks, and ECE is a trademark of WhisperKOOL. All rights reserved.

Mention of third-party products is for informational purposes only and constitutes neither an endorsement nor a recommendation. WhisperKOOL assumes no liability with regard to the performance or use of these products.

TABLE OF CONTENTS

Quick Reference Guide	2
Standard Controller Layout	4
Remote Controller Layout	4
Fan Speed.....	5
Unit Specifications	5
Introduction	6
Receiving and Inspecting the Unit	7
Quick Start Guide	8
Preparing the Wine Cellar	9
Pre-Installation	12
Through-the-Wall Installation	13
Preparing the Installation Location.....	13
Optional Exterior Grille	15
Installing the Unit	16
Ducted Installation	17
Ducting Overview.....	17
Ducting Configurations.....	18
Installing the Duct Plenums.....	20
Remote Controller Installation	21
Condensation Drain Line	23
Liquid Measuring Thermostat System (Bottle Probe)	24
Multi-Speed Fan Control	25
Unit Operation	26
Standard Controller	27
Functions	27
Alarm Codes	28
CPSM (Customer Preference Selection Mode).....	28
Standard Controller Wiring Schematic.....	29
Remote Controller	30
Functions	30
Alarm Codes	31
CPSM (Customer Preference Selection Mode).....	31
Remote Controller Wiring Schematic.....	32
Troubleshooting Guide	34
Maintenance Schedule	36
Technical Assistance	37
Accessories for Cooling Units	37
Product Warranty Information	38

QUICK REFERENCE GUIDE

Front / Side View

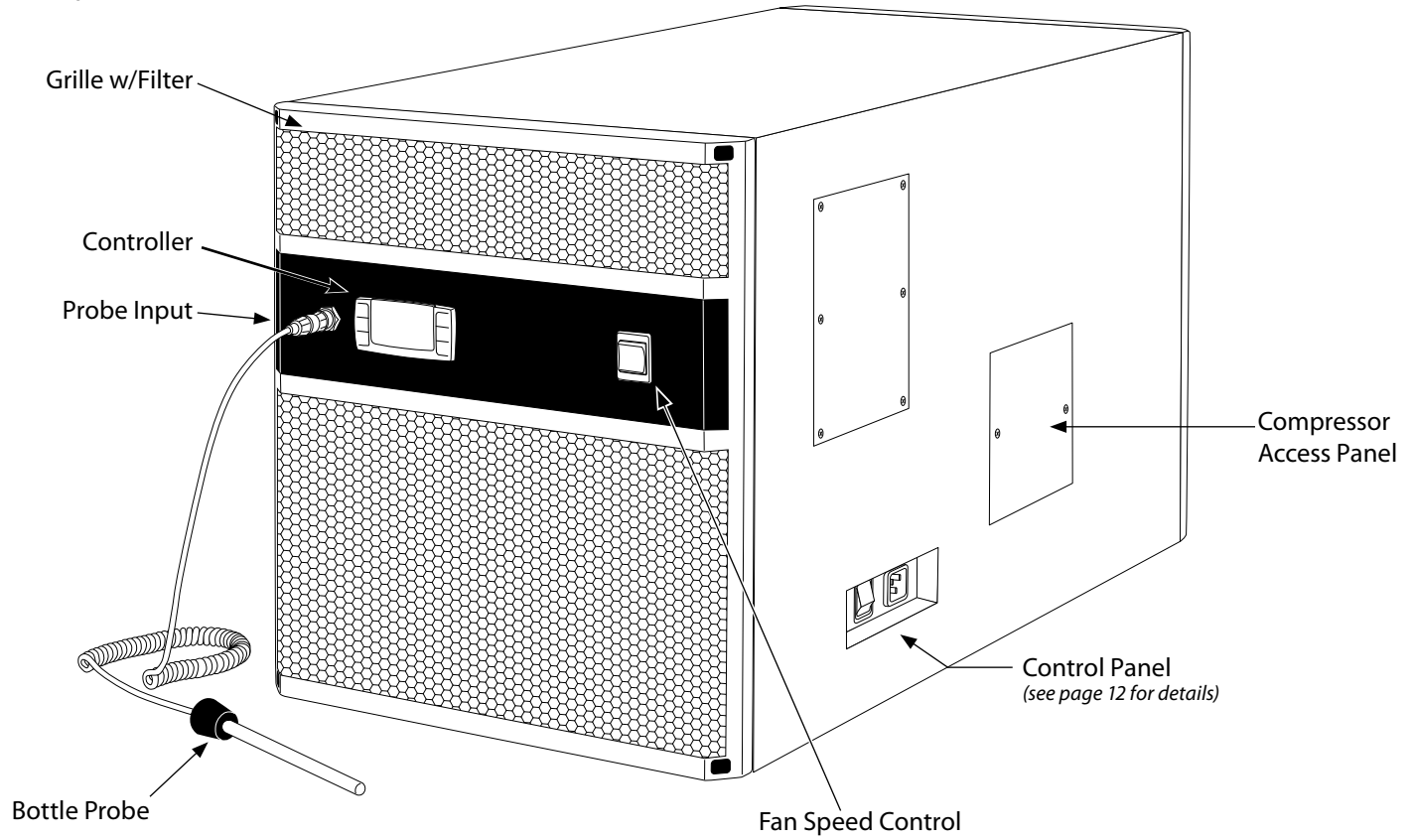

Rear / Side View

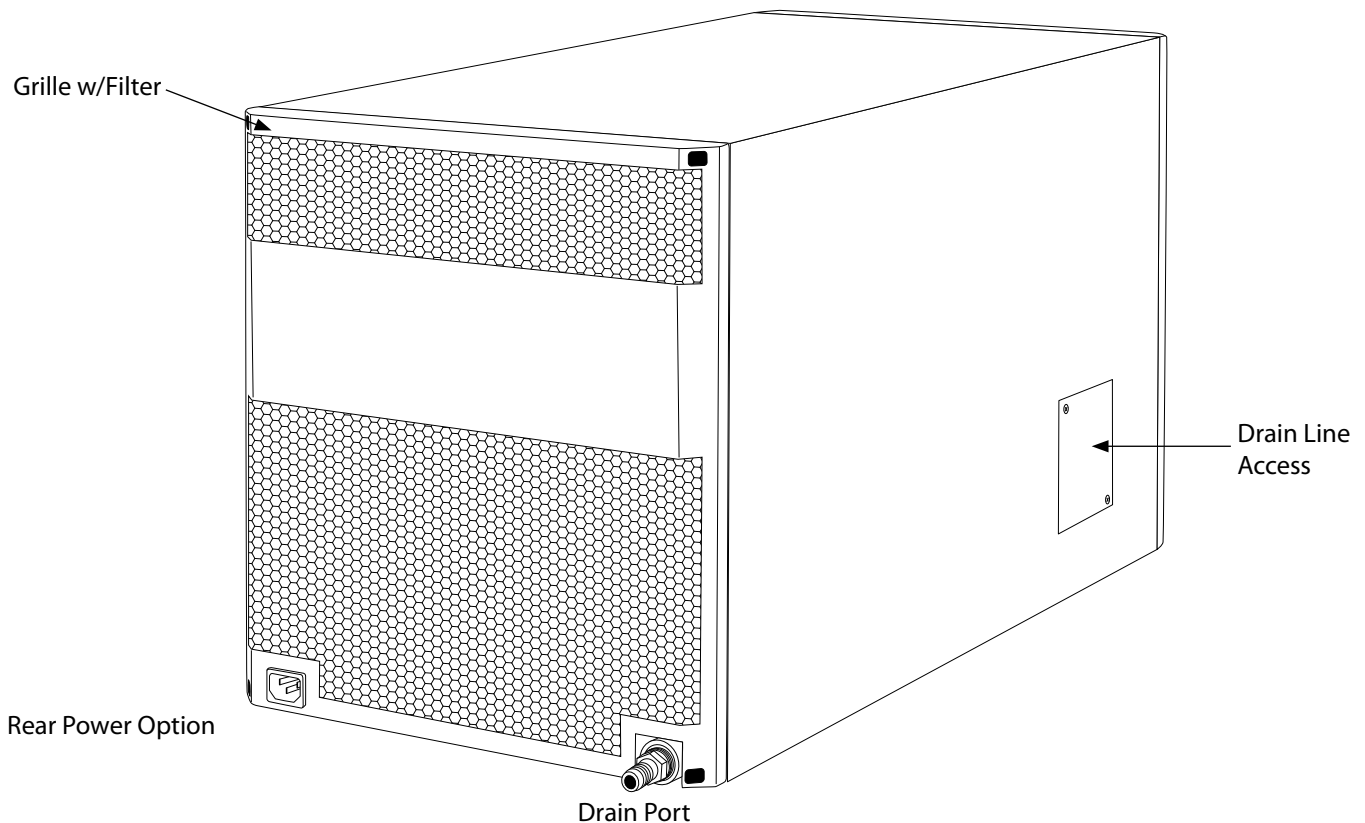

Remote Front / Side View

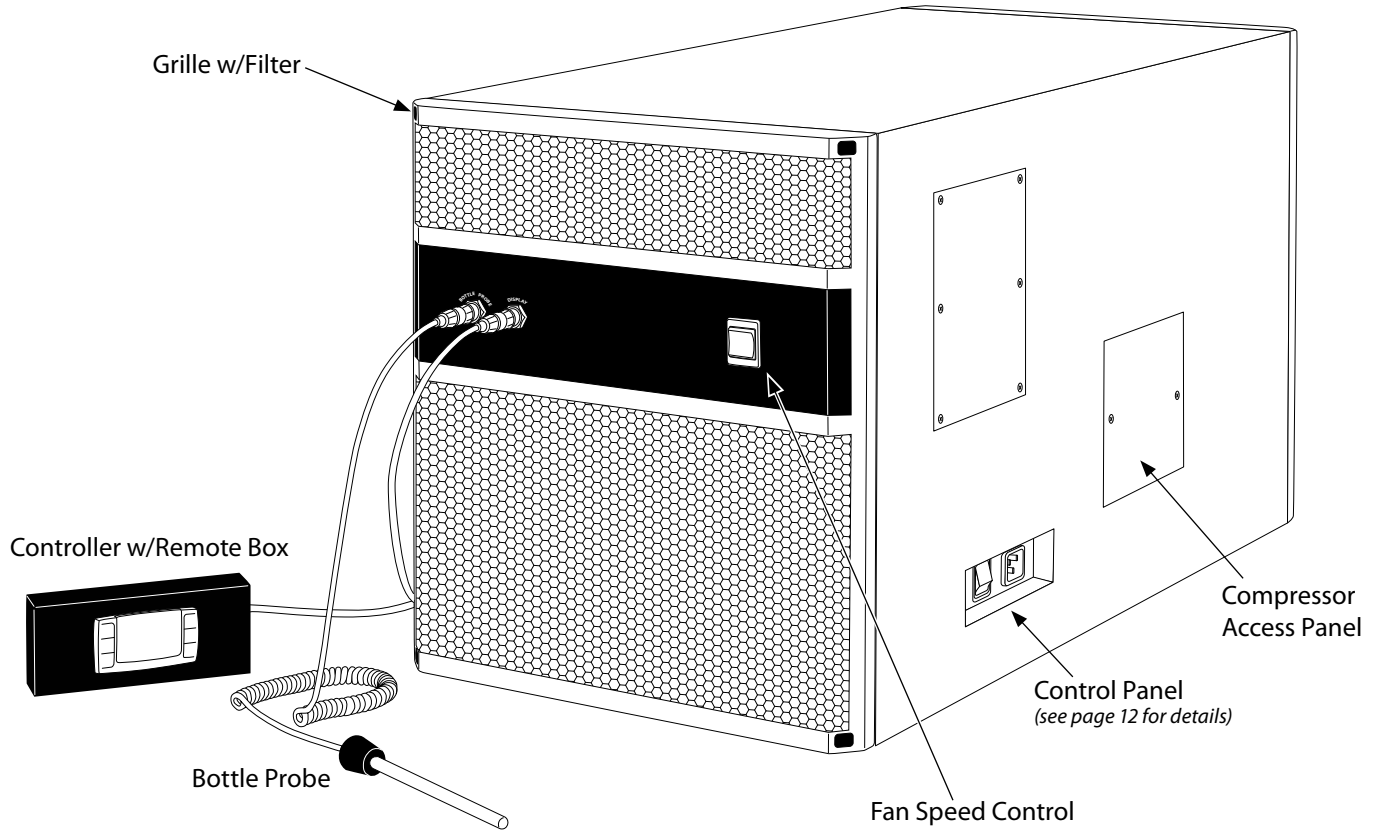

Fully Ducted — Front / Side View

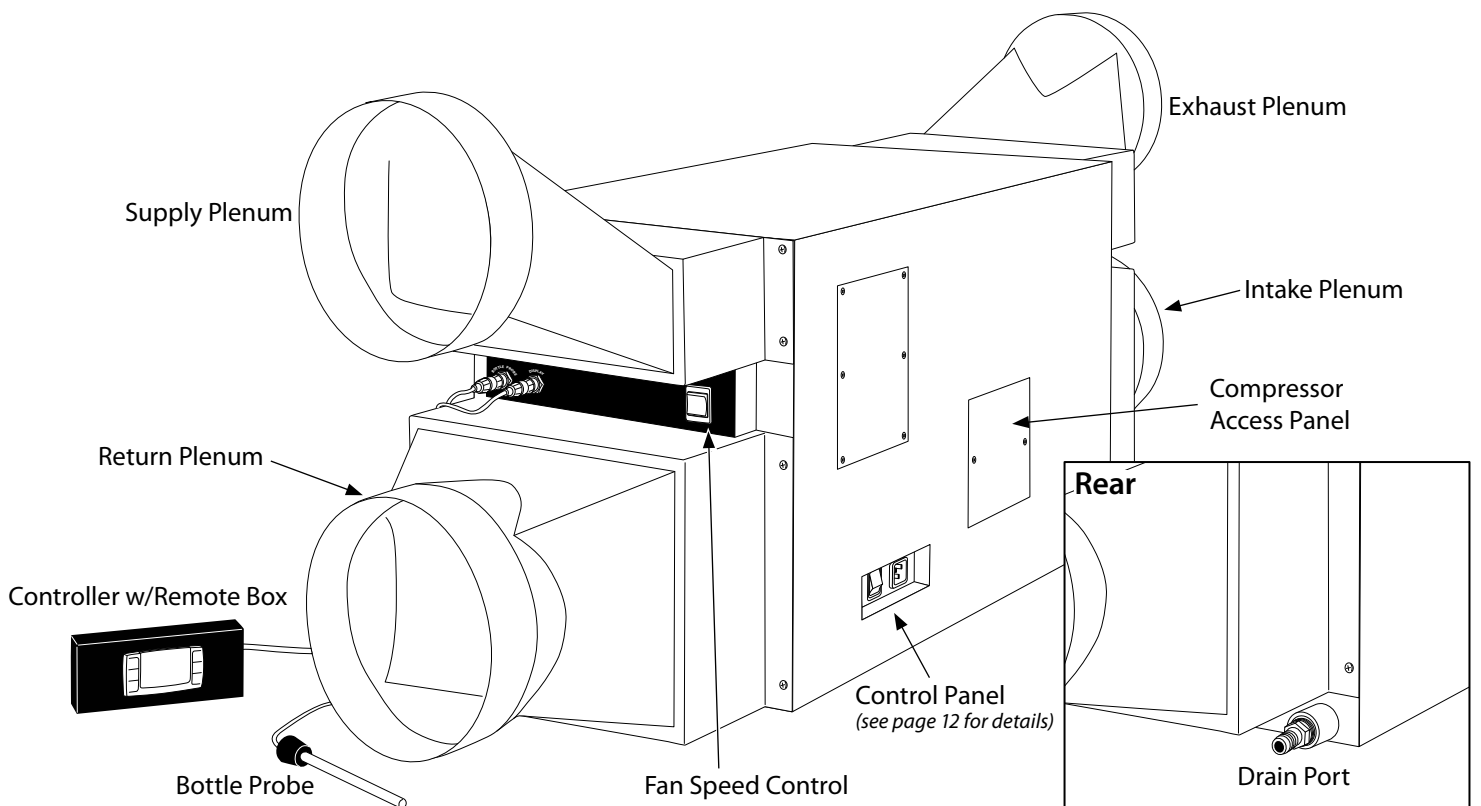

Standard Controller Layout

If your unit is installed through-the-wall and does not have a remote keypad you have the Standard Controller

Note: The 1 or 3–5 qualifies the amount of time in seconds that the button must be pushed to activate the feature.
Refer to page 30 for complete listing of buttons and symbols.

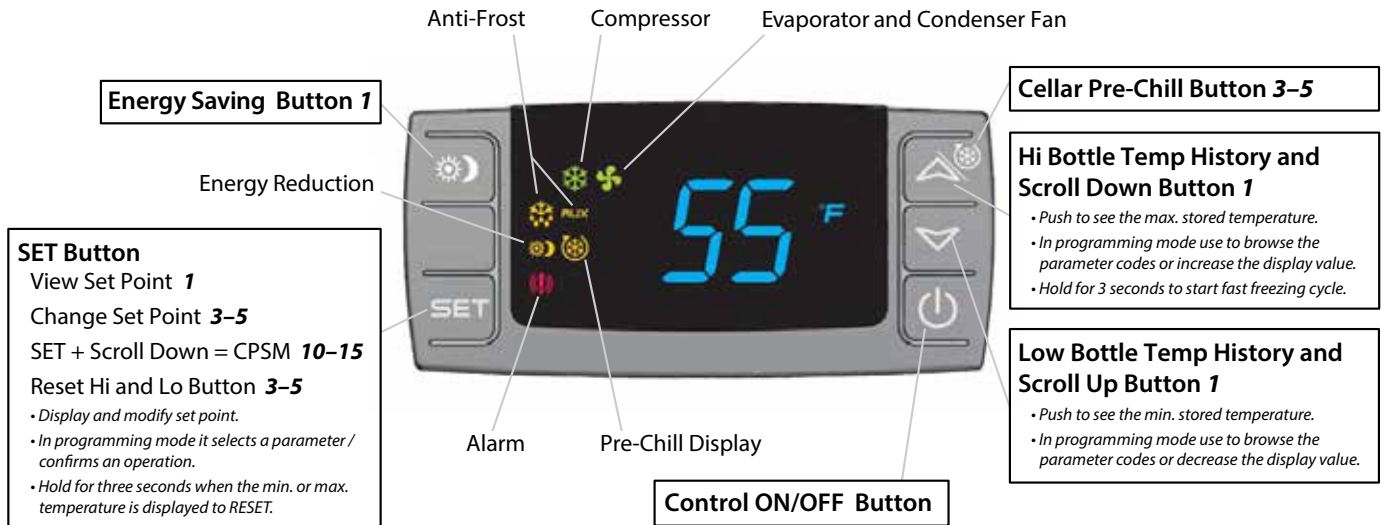

Remote Controller Layout

If your unit has a remote keypad then you have the Remote Controller

Note: The 1 or 3–5 qualifies the amount of time in seconds that the button must be pushed to activate the feature.
Refer to page 33 for complete listing of buttons and symbols.

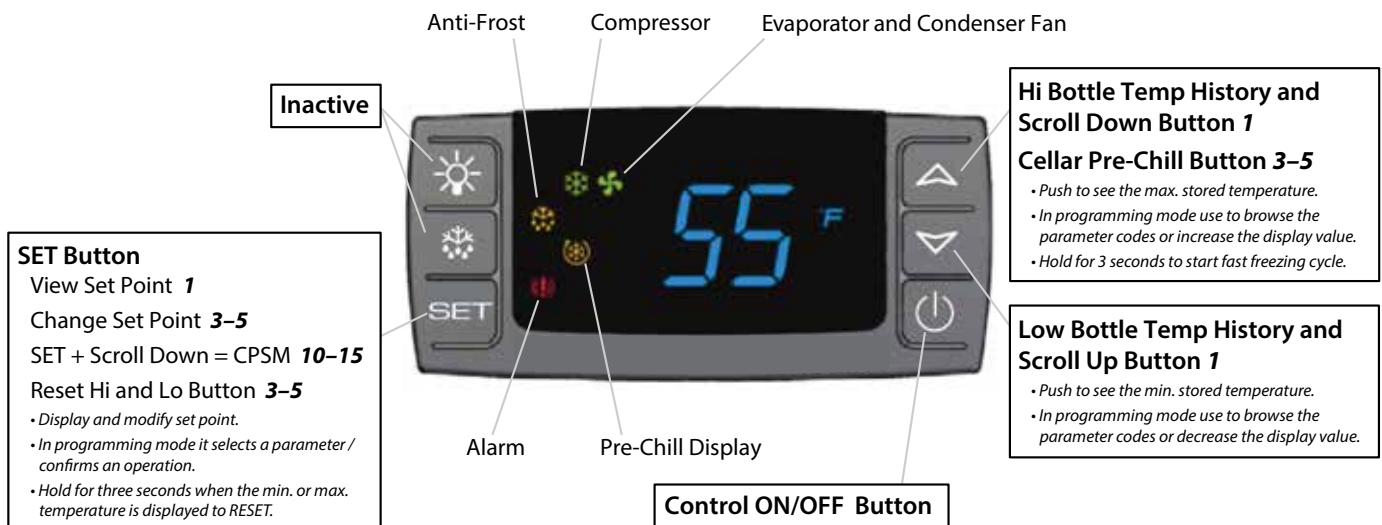

Fan Speed

Fan speed selection is determined by the amount of heat that needs to be removed from the cellar and the type of installation (through-the-wall or fully ducted). Fan speed selection is based on the cellar size, insulation factor, door seal and desired wine temperature. When initially installing the unit, set the fan speed to the **High** setting for a quick chill down. Once the wine cellar reaches the desired temperature, a lower fan speed may be selected (for all models except the Extreme 5000tiR FD). In the event that the outdoor temperature rises above 90°F, (when exhausting to the outdoors) a higher fan speed may be required.



Fully ducted units need to be set to the high fan speed position at all times.



All Extreme 5000tiR FD models come from the factory with the fans wired in high speed. The fan speed is not adjustable on these models.

	3500ti 3500tiR			5000ti 5000tiR			8000ti 8000tiR			5000tiR FD		
Speed Selection	Low	Med	High	Low	Med	High	Low	Med	High	Low	Med	High
Air Flow (CFM)	147	180	256	147	180	256	274	318	333	N/A	N/A	256
Sound (dBA* In Cellar / Out of Cellar)	51/51	58/57	66/65	51/51	58/57	66/65	57/57	59/59	60/61	N/A	N/A	66/65
Cooling Capacity (BTU/h)	2374	2514	2688	3099	3453	4126	5140	5606	5760	N/A	N/A	3794

* To get a feeling for decibels, a food blender at 3 ft. is 90 dBA, garbage disposal at 3 ft. is 85 dBA, vacuum cleaner at 10 ft. is 75 dBA, normal speech at 3 ft. is 79 dBA, dishwasher in the next room is 55 dBA, a quiet night is 35 dBA

Unit Specifications

	3500ti 3500tiR	5000ti 5000tiR	8000ti 8000tiR
Cellar Size*	800 cu. ft.	1250 cu. ft.	2000 cu.ft
Dimensions	14.25"W x 15.75"H x 28"D	14.25"W x 15.75"H x 28"D	14.25"W x 22.25"H x 28"D
Weight (lb.)	115	115	150
Amps (running)	9	9	10
dBA	51 low 58 med 66 high	51 low 58 med 66 high	57 low 59 med 61 high
Installation	Through-the-Wall, Partially Ducted, Fully Ducted		
Thermostat	Digital control display		
Temp. Delta	55°F temperature differential (maintains proper cellar temperature when exhaust environment does not exceed 110°F)		
Outside Venting	Can be done if the outside temperature does not exceed 110°F The external grille cover is required		
Ducting Options	Unit can be fully ducted		
Warranty	2-year parts and labor / 5-year compressor		

* Sizing the Unit to the Room

The specification chart will provide information on the units room size cooling capacity. There are circumstances in which a cellar design may require a larger unit due to some existing design restrictions. There are several factors such as glass, stone, concrete, etc. which will seem adequate but do not offer the insulation capacity required to maintain the optimum environment. We recommend purchasing a unit with a larger capacity to compensate for the design limitations. Under sized cooling units can lead to pre-mature failure and/or prevent the system from reaching the desired set temperature. As a result they are not covered under warranty.

INTRODUCTION

Customer Service

Thank you for purchasing a WhisperKOOL *Extreme Series* cooling unit. We strive to provide the highest quality products and the best possible customer service. If you have any questions about your WhisperKOOL unit, please call us at 1-800-343-9463 or visit whisperkool.com.

Using the Manual

This Owner's Manual is intended to assist in the proper installation and maintenance of the WhisperKOOL cooling unit. In order to ensure the longevity of your cooling unit, the equipment should be installed properly and have a proper care and maintenance schedule. Please read and review this Owner's Manual carefully and keep it for future reference.

What is the WhisperKOOL Cooling Unit?

The WhisperKOOL cooling unit is a specialized refrigeration unit designed for one purpose only: to maintain the optimal temperature and humidity levels conducive to the proper storage and aging of fine wines. It is a self-contained cooling unit designed to be used as a forced-air through-the-wall unit.

How Does the WhisperKOOL Extreme Series Work?

The WhisperKOOL unit is especially designed for the use and application to maintain optimal conditions for wine storage and aging. The unit is fully self-contained and can be installed as a through-the-wall application. The unit is also capable of a more flexible ducted application, which allows the unit to be placed in an indoor remote site, resulting in a quiet airflow. The standard through-the-wall and ducted units are temperature controlled via a bottle probe. The ducted unit comes standard with a remote controller that can be located up to 50 ft. from the cooling unit.

Note: Remote unit comes standard with a 50 ft. bottle probe and 50 ft. of cable for the remote controller, additional lengths are optional.

Temperature Setting

The WhisperKOOL cooling unit can be set at any temperature within the acceptable wine aging range of 50–67°F. It is designed to cool up to 55°F cooler than the ambient temperature of the space to which it is exhausting not to exceed 100°F.

RECEIVING AND INSPECTING THE UNIT

Upon Receiving the WhisperKOOL Cooling Unit

- Lift only at the designated hand hold locations on the shipping container or fully support the unit from underneath. A shipment may include one or more boxes containing accessories.
- Inspect the packaging for any obvious signs of damage or mishandling before opening the container.
- Note any discrepancies or visual damage on the Bill of Lading before signing.
- Place the box containing the WhisperKOOL unit on a tabletop to prepare it for testing prior to installing.
- Sit unit upright for 24 hours.

Note: WhisperKOOL units are manufactured in the USA and tested prior to shipment.

Review the Packing Slip to Verify Contents

- Check the model number to ensure it is correct.
- Check that all factory options ordered are listed.

If any items listed on the packing slip do not match your order information, contact WhisperKOOL Customer Service immediately.

Check the Box for the Following Contents:

3500ti / 5000ti / 8000ti	3500tiR / 5000tiR / 8000tiR
<p>Extreme Cooling Unit</p> <ul style="list-style-type: none"> • WhisperKOOL Extreme Series Owner’s Manual <p>Single Piece Mounting Bracket</p> <p>Accessory Kit:</p> <ul style="list-style-type: none"> • 8’ Power Cord • Mounting Bracket Insulation 14.5” Foam (2) • Mounting Bracket Insulation 24.75” Foam (2) • Bottle Temperature Probe • 1¼ Standard Screws (9) • ½ Self-Tapping Screws (5) • ½ x ½ Barbx MNPT Fitting • Drain Line tube 10’ (1) • Connection “T” (1) 	<p>Extreme Cooling Unit</p> <ul style="list-style-type: none"> • Remote Controller • Bottle Temperature Probe • WhisperKOOL Extreme Series Owner’s Manual <p>Single Piece Mounting Bracket</p> <p>Accessory Kit:</p> <ul style="list-style-type: none"> • 8’ Power Cord • Mounting Bracket Insulation 14.5” Foam (2) • Mounting Bracket Insulation 24.75” Foam (2) • 1¼ Standard Screws (9) • ½ Self-Tapping Screws (5) • ½ x ½ Barbx MNPT Fitting • Drain Line tube 10’ (1) • Connection “T” (1)

Please leave the WhisperKOOL unit in its original box until you are ready for installation. This will allow you to move the product safely without damaging it. When you are ready to remove the product from the box, refer to the installation instructions.

TIP: Save your box and all packaging materials. They provide the only safe means of transporting/shipping the unit.

QUICK START GUIDE

This guide is meant to serve as a quick reference for installation of the WhisperKOOL unit. The remainder of this Owner's Manual will provide more detailed information and instructions.

Upon Receiving the WhisperKOOL Cooling Unit

1. **Inspect the unit before installation.** If damage is found, please contact your distributor or WhisperKOOL Customer Service at 1-800-343-9463 ext. 799.
2. The unit should **remain in an upright position for 24 hours** prior to operation.
3. The WhisperKOOL unit **requires a dedicated 115V 20A circuit.** Use a surge protector with the WhisperKOOL unit. **Do not use a GFI** (Ground Fault Interrupter) line.
4. For your convenience, the WhisperKOOL unit has two power inlets: one on the side of the unit, and the other on the back. Use the selector switch, located on the right side of the unit, to select the inlet you would like to use.
5. It is **Required to install a drain line** to remove condensation from the unit.
6. The WhisperKOOL unit is intended **for use in properly designed and constructed wine cellars.** Hire a professional wine storage consultant with a valid contractor's license to build your wine cellar. Refer to the *How to Build a Wine Cellar* video available on the WhisperKOOL website at www.whisperkool.com.
7. Install the foam strips along the inside edge of the unit's flange to assure a proper seal against the wall.

Never try to open the WhisperKOOL unit, repair it yourself, or use a service company without WhisperKOOL's authorization. This will void your warranty.

If you encounter a problem with your WhisperKOOL unit, please refer to the Troubleshooting Guide on page 36. If you have any further questions, concerns, or need assistance, please contact WhisperKOOL Customer Service at 1-800-343-9463 ext. 799. Please be sure all testing has been completed prior to contacting Customer Service. Please have your results ready for your representative.

PREPARING THE WINE CELLAR

The performance and life of your WhisperKOOL unit is contingent upon the steps you take in preparing the wine cellar.

Note: Improperly preparing your enclosure or incorrectly installing your WhisperKOOL unit may cause unit failure, leaking of condensation, and other negative side effects.

It is highly recommended that you obtain the assistance of a wine storage professional.

Wine storage professionals work with licensed contractors, refrigeration technicians, and racking companies to build well insulated, beautiful, and protective wine cellars. WhisperKOOL has provided useful tips to assist in the installation process. Our recommendations are meant to act as a guide in the process of building a proper enclosure. Your intended location may have specific needs that we do not address.

How to Build a Wine Cellar Instructional Video

WhisperKOOL has a tutorial available online at www.whisperkool.com. This tutorial will walk you through the steps of constructing a properly built wine cellar and the installation of the WhisperKOOL product line.

Wall and Ceiling Framing

Build wine cellar walls using standard 2x4 or 2x6 construction methods and ceiling joists following the guidelines of local and state codes in your area. As a general rule, the thicker the walls and the higher the insulation value in your cellar, the better it will be at maintaining a consistent temperature.

Insulation

Insulation is **Required** with the use of the WhisperKOOL product. Standard fiberglass or rigid foam insulation is normally used in cellar construction or, in some cases, "blown-in" insulation is used. It is very important that all walls and ceilings are insulated to keep the cellar temperature as consistent as possible during the summer and winter months. The R-value, or quality of insulation, is determined by the rate at which heat passes through the insulation. The higher the R-value, the more resistant the insulation is to conducting heat. Using higher R-values in insulation will lower your operating costs and unit run time (R-13 minimum, R-19 recommended, R-30 for ceiling and exterior walls).

Vapor Barrier

Water vapor creates its own pressure (separate from the air pressure) and will intrude into colder/drier areas. A vapor barrier is **Required** to prevent the intrusion of water vapor so that the cellar can be kept at the correct temperature and humidity. 6 mm plastic sheeting (recommended) should be applied to the warm side of the cellar walls. The vapor barrier must also be applied to the outside walls and ceiling. If it is impossible to reach the outside, then the plastic must be applied from within the cellar. The most common method is to wrap the entire interior, leaving the plastic loose in the stud cavity so the insulation can be placed between each stud. All of the walls and ceiling must be wrapped in plastic for a complete vapor barrier.

In areas of high humidity, such as Southern and Gulf States, the vapor barrier will prevent infiltration of warm, moist air. The moist air can cause mold to form, and standing water in drain pans promote microbial and fungal growth that cause unpleasant odors and indoor air quality problems. If mold is found, remove it immediately and sanitize that portion of the unit.

Note: High humidity significantly increases the heat load on the cooling system.

Any break in the vapor barriers (cut, nail hole, over-lapping, etc.) will allow a moisture leak and must be sealed. The electric conduit is a "duct" for vapor to travel in. The conduit should be caulked and sealed on the warm air end.

Mounting the Unit

The unit must be mounted within 18" of the top of the room in order to achieve sufficient cooling. As the room cools down, the warm air will rise to the ceiling. Mounting the unit high in the room will create a consistently cool environment by capturing the warm air and replacing it with cool air. Mounting the unit low in the room will result in a temperature variation in the room due to the unit's inability to draw warm air from the ceiling of the cellar to the unit itself, and cold air settling to the floor.

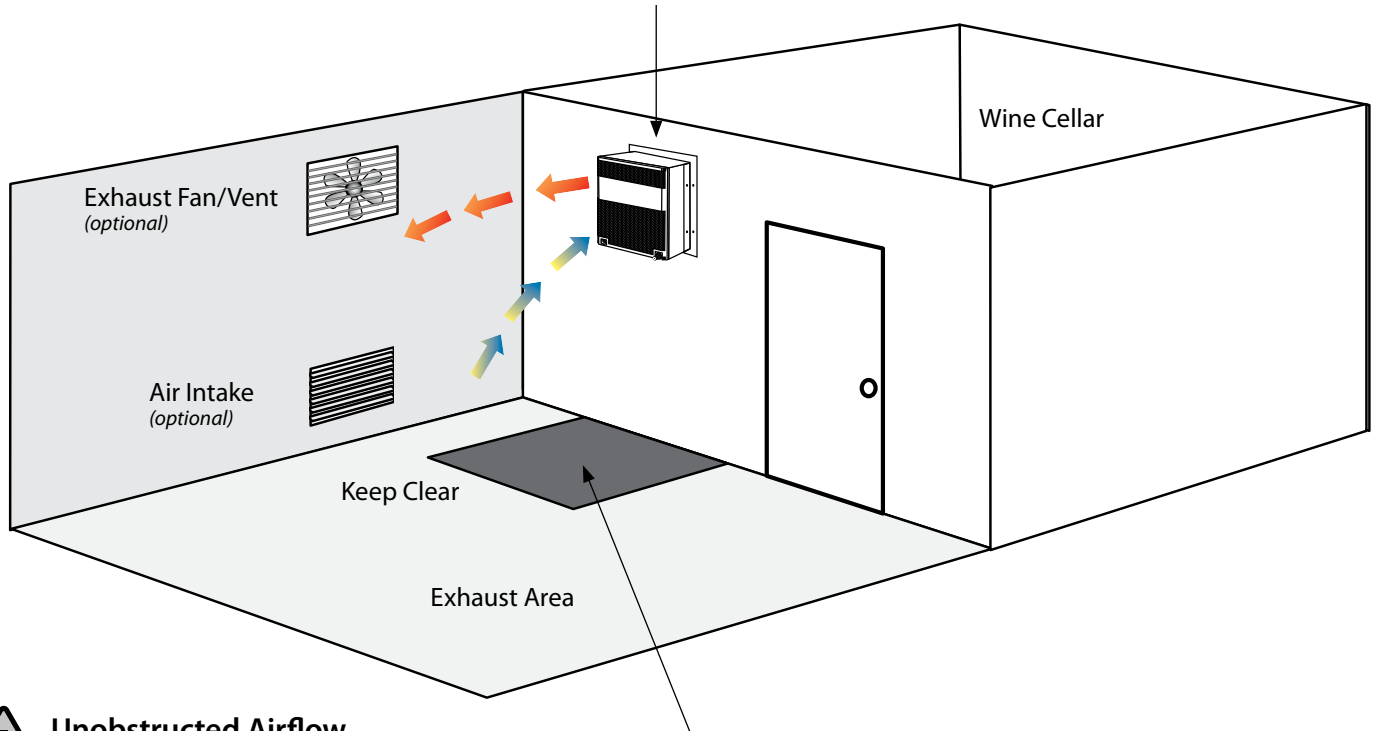

Unobstructed Airflow

Unobstructed airflow to and from the unit is critical for the unit's overall performance and life span. A minimum three-foot clearance (five-foot is ideal) area is crucial. The air blown by the fans needs to circulate and either dissipate or absorb heat from the space. The system will operate more efficiently with a greater amount of air to exchange.

Note: Avoid attempting to camouflage the unit. This will restrict airflow, and thus the unit's ability to work efficiently.

Door and Door Seal

An exterior grade (1¾") door must be installed as a cellar door. It is very important that weather stripping is attached to all four sides of the doorjamb. A bottom "sweep" or threshold is also required. The door must have a very good seal to keep the cool cellar air from escaping out of the cellar. One of the most common problems with cooling units running continually is due to the door not sealing properly. In cases where glass doors are used and the room size is close to the recommended unit size, the next larger size WhisperKOOL should be used. This will compensate for the insulation loss due to the lower insulating rating of glass.

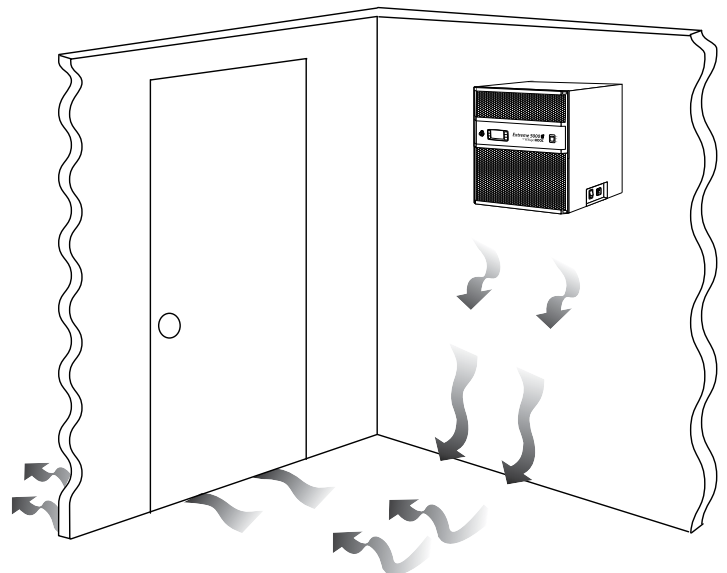

Ventilation

The necessity of dissipating heat away from the unit is critical to the unit’s performance and cannot be overstated. As the unit operates and cools, a greater amount of heat is generated on the exhaust side of the unit. Adequate ventilation is required in order to dissipate heat away from the unit. If ventilation is inadequate, the exhaust will heat the area or room and adversely affect the unit’s ability to cool. In some cases, it may be advisable to install a vent fan to dissipate heat from within the exhaust area. However, you must have a fresh air inlet as well. If your unit requires ducting, please contact WhisperKOOL to obtain a specially designed ducting plenum for the unit.

Using any other ducting system will void the warranty.

Note: If you are unsure about having adequate ventilation in your install location, please contact us to assess your specific installation at support@whisperkool.com or 1-800-343-9463.

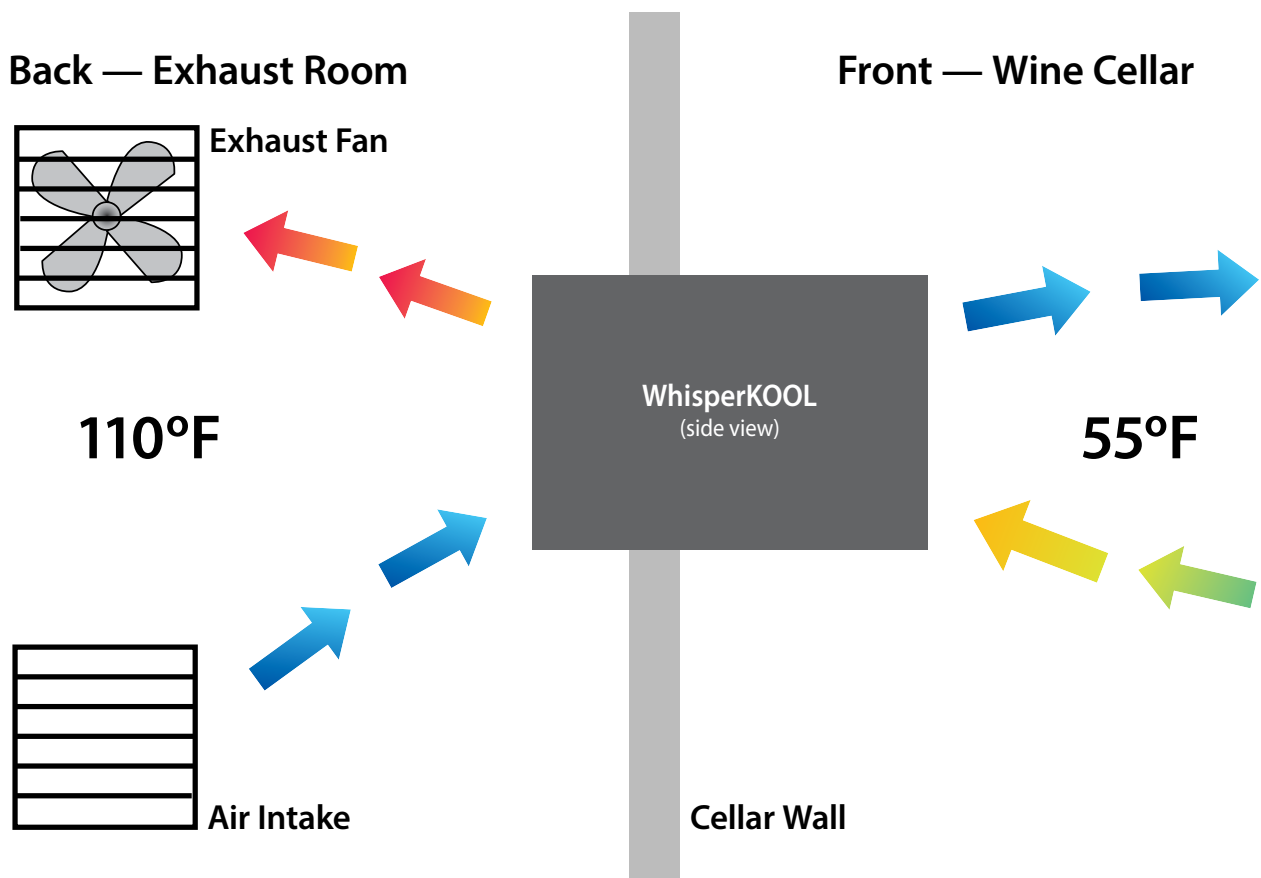

Ambient Temperature Factor

The cooling unit has the ability to cool a wine cellar efficiently to 55°F as long as the ambient temperature of the area that it is exhausting to does not exceed 110°F. Therefore, you want to exhaust the unit in a room which will not exceed 110°F. Without proper heat dissipation the unit will not have the capacity to keep the wine at a desirable 55°F.

⚠ WARNING! Allowing your unit to operate in high ambient temperatures for extended periods of time will greatly decrease the life of your unit and void your warranty. ⚠

PRE-INSTALLATION

To prepare the unit for testing before installation in wall

- Unit needs to be in the upright position for 24 hours before starting
- Remove unit from box

Electrical Needs

The WhisperKOOL Unit requires a dedicated 115V 20A circuit. The unit draws a large amount of amps at initial start up. By designating a dedicated circuit breaker, you will guarantee the unit has enough power to run effectively. Contact an electrician for assistance with the installation of this dedicated electrical circuit:

- Match the electrical outlet to the plug provided on the WhisperKOOL unit.
- Provide a dedicated circuit and wiring for the unit.
- Provide a weatherproof plug for units connected outside.

Plug your WhisperKOOL unit into a surge protector or power conditioner. As with any sensitive electrical equipment, the WhisperKOOL electrical equipment may be damaged by power surges and spikes. Power surges and spikes are not covered under warranty.

We recommend that you do not use a GFI (Ground Fault Interrupter) with this product.

Electrical Inlets

The unit is equipped with two power inlets. One is located on the right side of the unit, (inside of the cellar) the other is located on the rear of the unit (outside of the cellar). Use the selector switch located on the right side of the unit to select which power inlet you would like to utilize. If you would like to plug the unit into a socket outside of the cellar, set the selector switch to rear. If you would like to plug the unit into a socket inside of the cellar, set the selector switch to the front position. When placed in either position, power can only enter the unit utilizing the power inlet you've selected.

In case the unit should lose power, check the home/main circuit breaker. If the unit does not respond properly, refer to the Troubleshooting Guide.

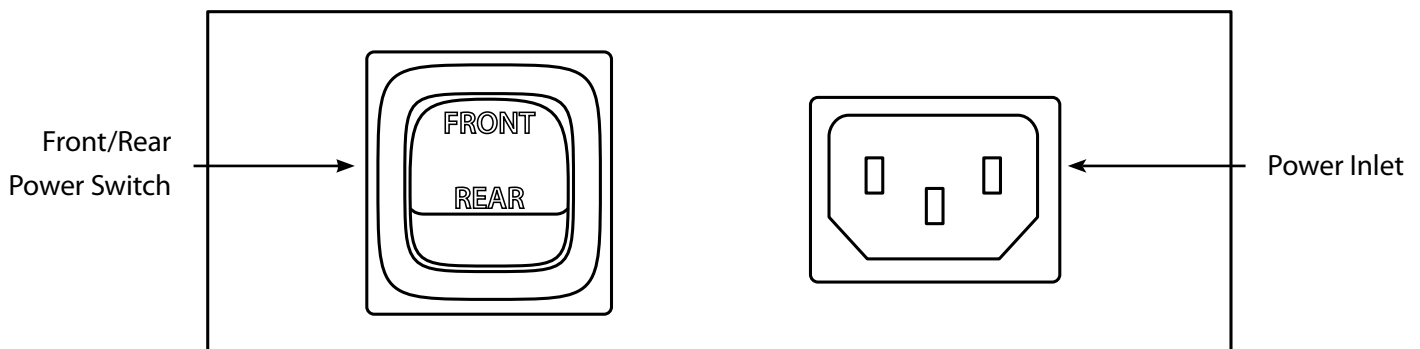

THROUGH-THE-WALL INSTALLATION

Preparing the Installation Location

Minimum Tools Needed

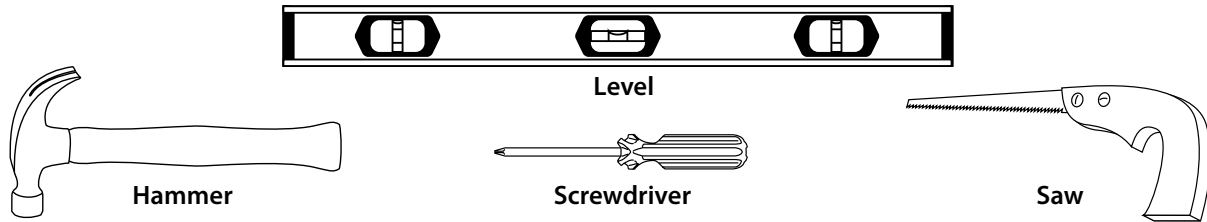

Locate the desired installation location (no lower than 18" inches from the ceiling). Using a stud finder, locate the studs on either side of the center point, and mark them with vertical lines.

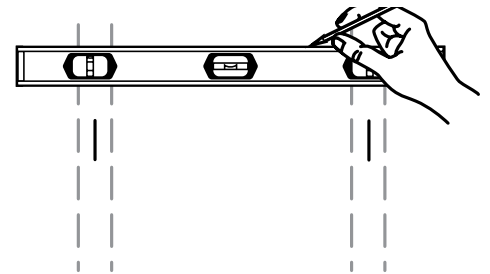

Using a level and a pencil, mark a horizontal line on the wall between the two studs, no less than 1.5" and no more than 18" from the ceiling.

Using a ruler or measuring tape, measure 16" down (3500ti/tiR & 5000ti/tiR) or 22.75" down (8000 ti/tiR), and mark another horizontal line parallel to the first one.

Using a saw, cut along the uppermost horizontal line until your saw reaches the stud. Turn the saw around, inserting it into the cut that has just been made, and cut toward the opposite stud so that there is a clean horizontal cut between the two studs. Be careful not to cut into the studs themselves.

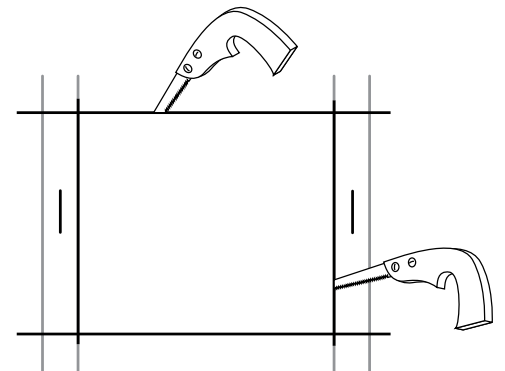

Make the second horizontal cut from stud to stud on the line 16" below the first cut.

Once the horizontal lines have been cut, make vertical cuts using the inside edge of the studs as a guide. Once both vertical cuts have been made, there should be a rectangular hole in the sheetrock. Make the same hole on the other side of the wall. Using a nail, mark all four corners of the first hole by making nail holes through the sheetrock. Connect the holes with a pencil mark and cut on the other side of the wall.

Sheetrock alone cannot support the weight of a 96 lb. cooling unit. Therefore, it is necessary to frame the hole that has just been cut with upper and lower supports. These supports also provide solid material for the mounting bracket screws.

Using two 2x4s at 14.5" in length and eight 6d nails, secure the upper and lower supports to the right and left studs, just inside the sheetrock. Make sure that the internal height remains at 16" (3500ti/tiR & 5000ti/tiR) or 22.75" (8000 ti/tiR) so that the WhisperKOOL unit will fit snugly through the framed cut-out.

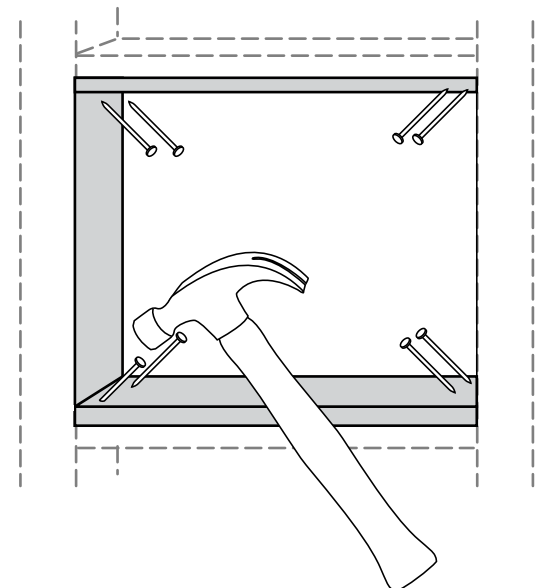

Single Piece Mounting Bracket

This sturdy bracket is used to frame the installation location and secures the unit to the wall studs. The bracket has been designed to hold the unit at a 2° angle, this helps project the air into the space and aids in condensation drainage.

Applying Insulation Tape

Locate the four pre-cut pieces of black foam tape included with the unit, two larger pieces and two smaller pieces. To apply, simply peel back the white-paper adhesive covering and place on the mounting bracket. The large pieces are applied to the top and bottom while the smaller pieces are for the sides. This foam creates a tight seal between the bracket and the wall.

Mounting Bracket Installation

Select your desired bracket mounting location (see diagram below), this location determines the depth of the installation. For example, position #1 keeps most of the unit out of the cellar while position #4 sets the back of the unit near flush on the exterior wall. Slide bracket onto unit, pay special attention that the TOP label on the bracket and the unit mounting flanges are towards the back. Use the four supplied 1/2" self tapping screws to fasten the bracket to the unit. It is imperative to not use self tapping screws longer than 1/2" in length.

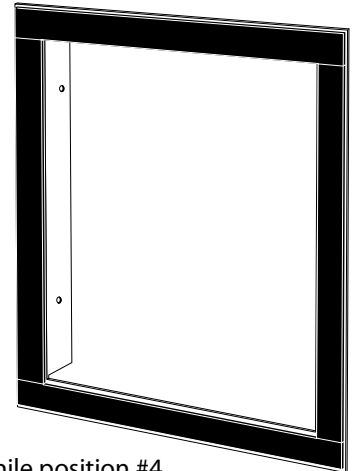

If you are installing through an exterior wall, please review the next page for specific instructions on exterior grill installation.

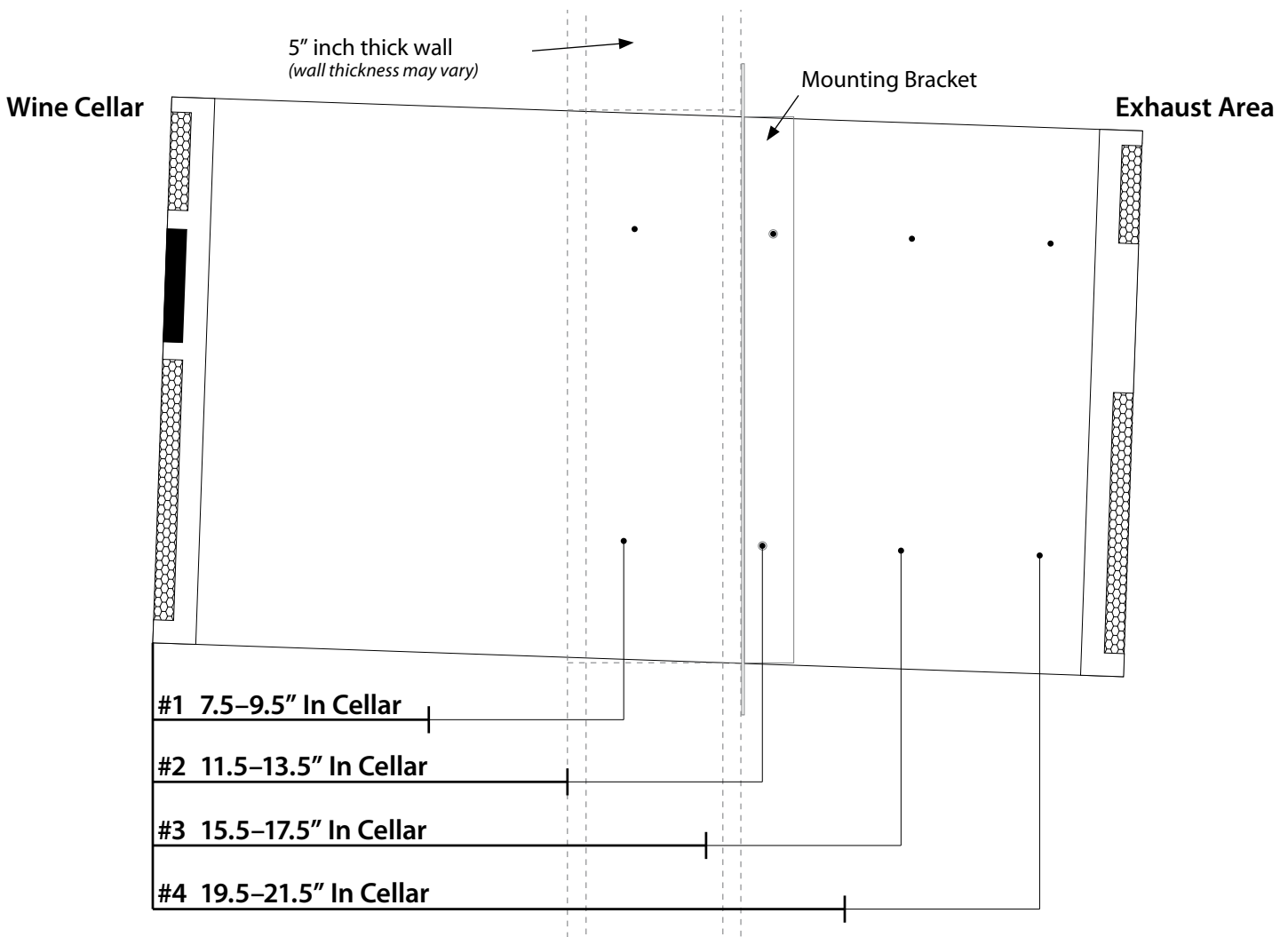

Optional Exterior Grille

Exterior Grille Installation

The exterior grille is required on all installations where the exhaust side of the unit is exposed to the outdoors (i.e. rain and weather).

Non-Flush Installation

Install the unit according to the standard through-the-wall procedure. After the unit is installed, place the exterior grille over the exhaust side filer grille and line up the screw holes on the top, bottom, and sides. Use the supplied eight self tapping screws to fasten the grille to the unit.

Flush Installation

This installation is slightly different because you are utilizing the same holes for both the mounting bracket and exterior grille.

1. Slide the mounting bracket onto the unit followed by the exterior grille, bring the two pieces together by sliding the exterior grille over the mounting bracket side flanges.
2. Align the two top screw holes of the exterior grill with the top screw locations on the unit, use the supplied self tapping screws to fasten the grille.
3. Repeat step 2 on the bottom of the unit.
4. Use the supplied self tapping screws to fasten the grille and bracket to the unit ensuring the bracket stays perpendicular/square.
5. Continue through-the-wall installation.

It is required to use the 1/2" self tapping screws provided. Do not drill holes into unit.

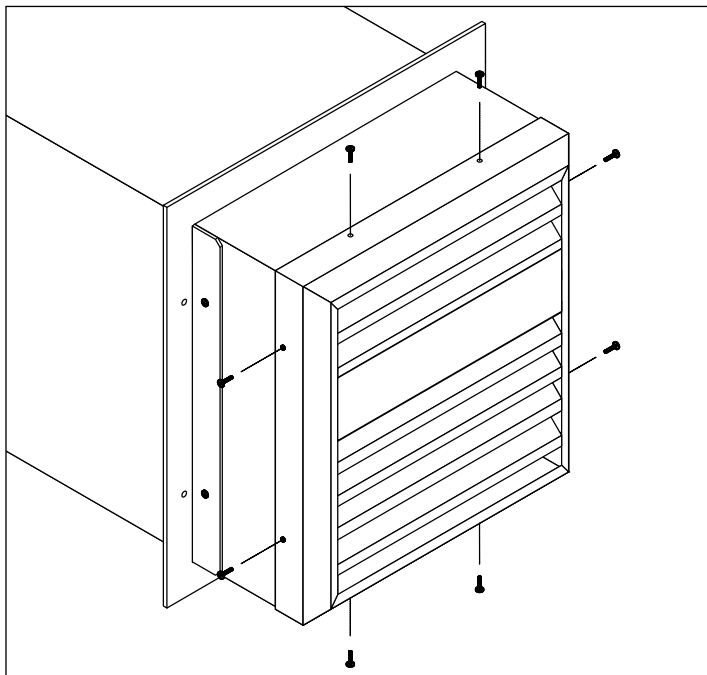

Non-Flush Installation

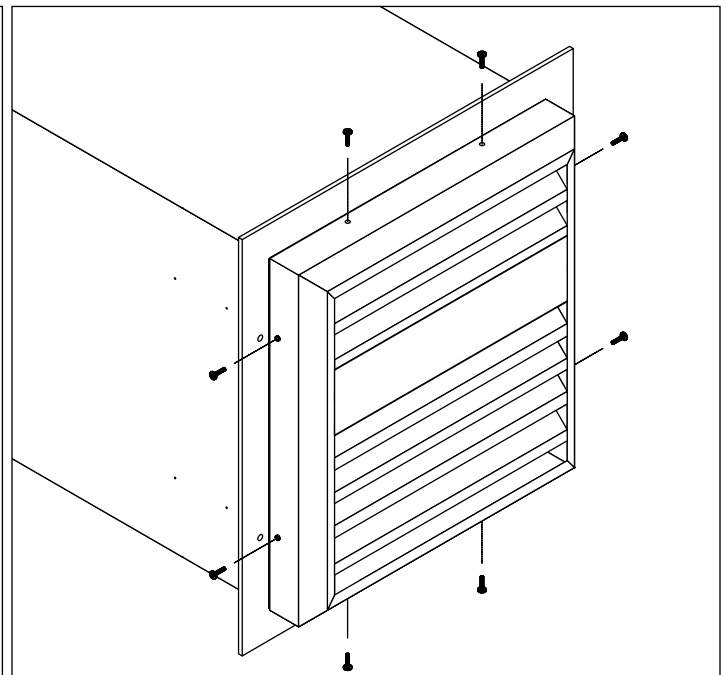

Flush Installation

Installing the Unit

Slide the unit from the outside wall into your wine cellar with the outer flange flush to the wall. Secure the flange to the wall through the pre-drilled holes. The screws should penetrate the studs as well as the upper and lower supports to provide adequate support for the WhisperKOOL unit (see illustration). Seal all cracks and gaps around the WhisperKOOL Extreme unit with an air-tight sealant or caulking to prevent air leakage.

Note: If you use decorative moulding, it should be attached to the walls and never to the cooling unit itself. The moulding itself should be removable in case the unit needs servicing

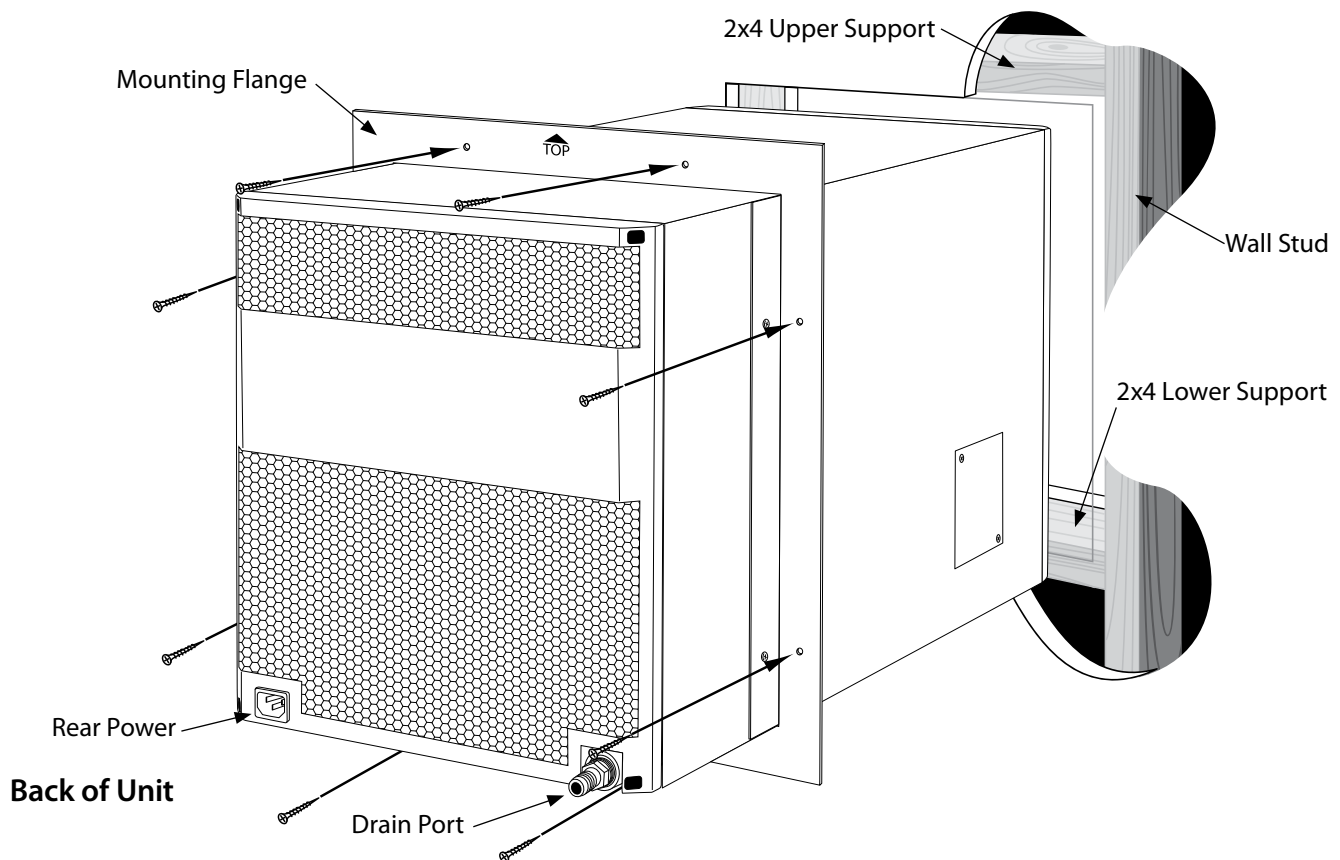

DUCTED INSTALLATION

Ducting Overview

Use of Ductwork

Use ductwork to connect the unit to the supply and return outlets in the wine cellar. Use only insulated ductwork to minimize cooling losses, prevent sweating and reduce noise. Use ductwork on the condenser section to redirect or absorb sound, bring in outside air to the unit inlet, and/or exhaust the hot air.

Note: Do not exceed a total of 25' for each length of ductwork run and a total of 50' combined for both the supply and return lengths.

Avoid crimping the flexible ducts. This chokes down the inside area and reduces the airflow causing the unit to operate improperly. Be sure all duct work and outer surfaces in contact with the airflow are insulated and have a vapor barrier on the outside. Un-insulated supply and return ducts may cause bare, exposed metal surfaces to sweat, further degrading the insulation and equipment cooling capacity.



Do not allow sharp turns to squeeze or decrease the inside diameter of the flexible ducting.



General Duct Recommendations

- Provide support for the flexible duct to prevent sags and bends.
- 3500tiR & 5000tiR Duct Size: 8" Supply and Return (Set the 5000 model to the highest fan speed)
- 8000tiR Duct Size: 8" Supply and 10" Return
- Stretch out the duct to make a smoother interior which reduces air resistance.
- Maximum duct length is 25'.
- For 90° bends, use a 90° adjustable elbow.
- No more than two 90° bends on each duct. Sweep 90° bends are recommended rather than sharp 90° bends.
- Generously apply duct sealant to all metal seams to fill in gaps that can leak air. Allow sealant to dry until firm to the touch before applying fiberglass insulation.
- Do not squeeze or reduce the inside diameter of the ducts as this will reduce airflow.
- Use short and straight ductwork where possible.
- Check that all fan blades move freely.
- Keep air paths free of loose foreign objects and debris.
- To provide adequate airflow the fan speed must be set to high when the unit is ducted.

Return Grilles

Locate the supply and return grilles inside the cellar to create an airflow pattern that maximizes air circulation in the room. Avoid short circulation of the air.

Do not

- Install through-the-wall return air grilles at floor level, as they will collect dust from the floor.
- Mount the unit lower than 18" from the ceiling.
- Locate the supply or return air grille where it is blocked by bottles, boxes or cases.

Ducting Configurations

There are a variety of ways to duct this unit, please review the different configurations to determine a basis for your particular installation. Remember to contact a wine cellar professional if you have any questions.

Half Duct Configuration

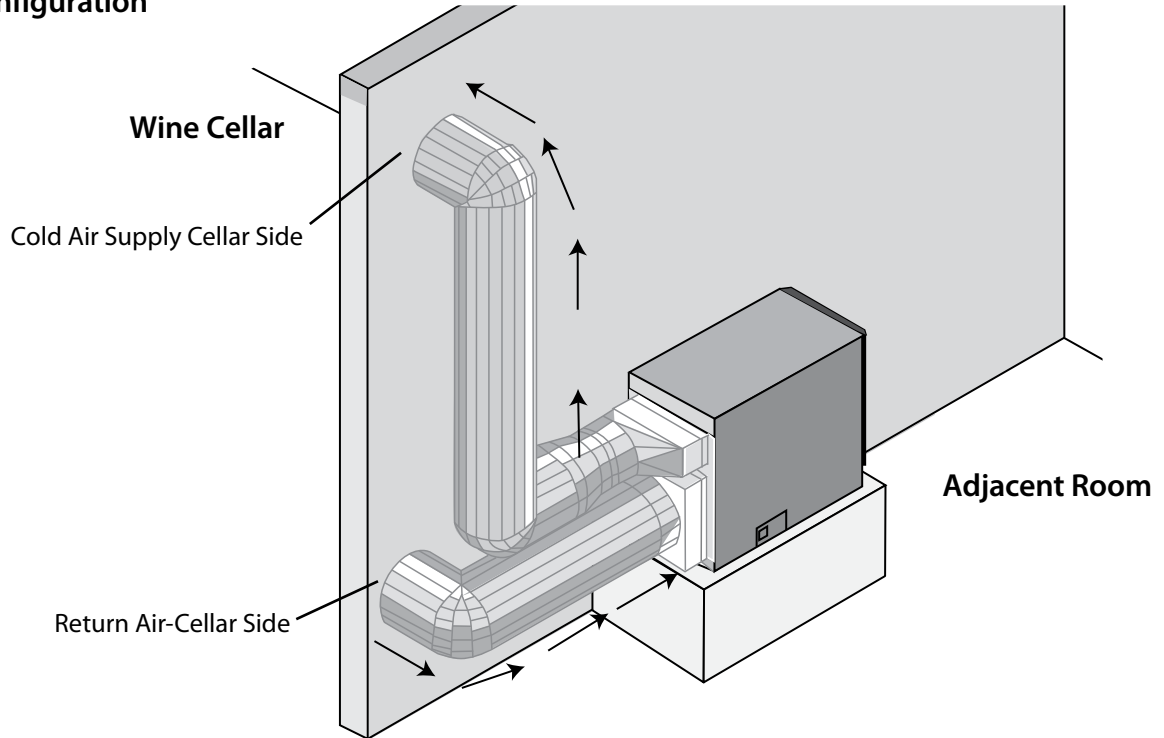

Three-Quarter Duct Configuration

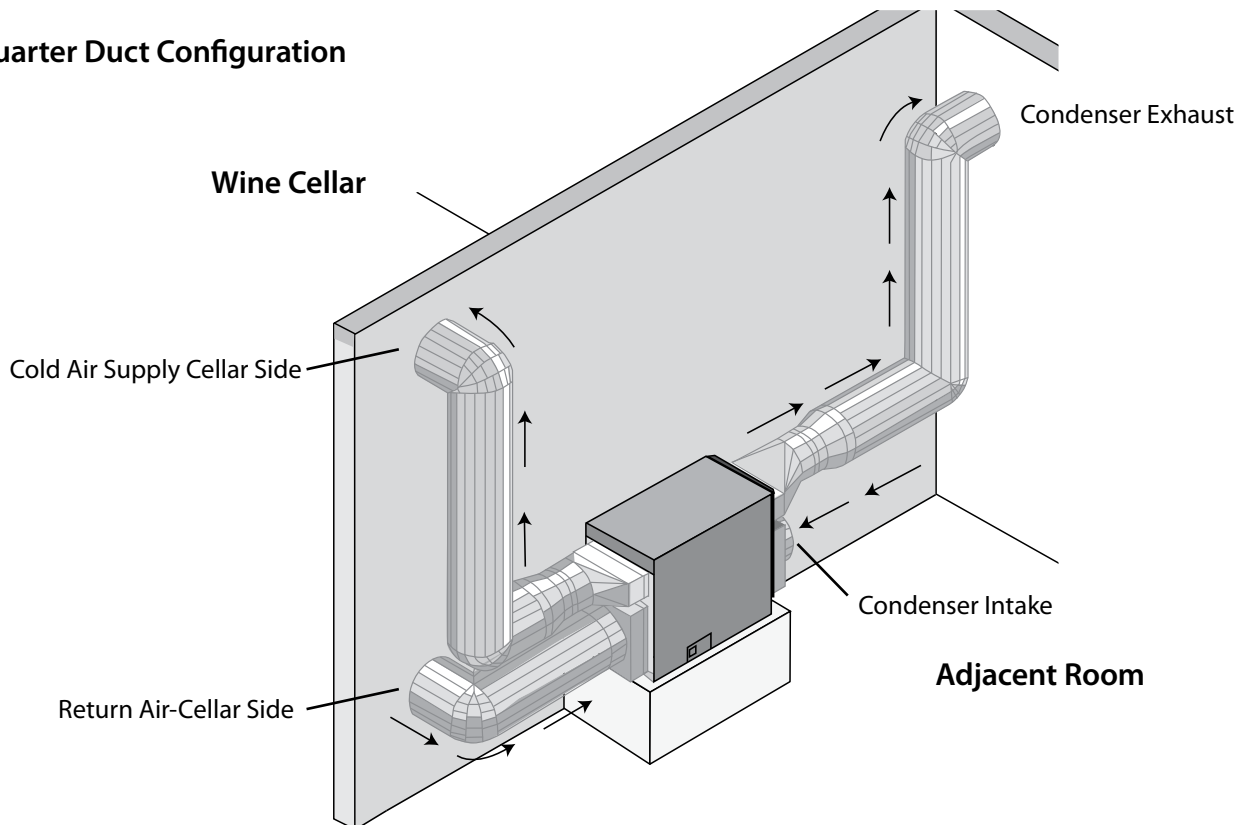

Fully Ducted

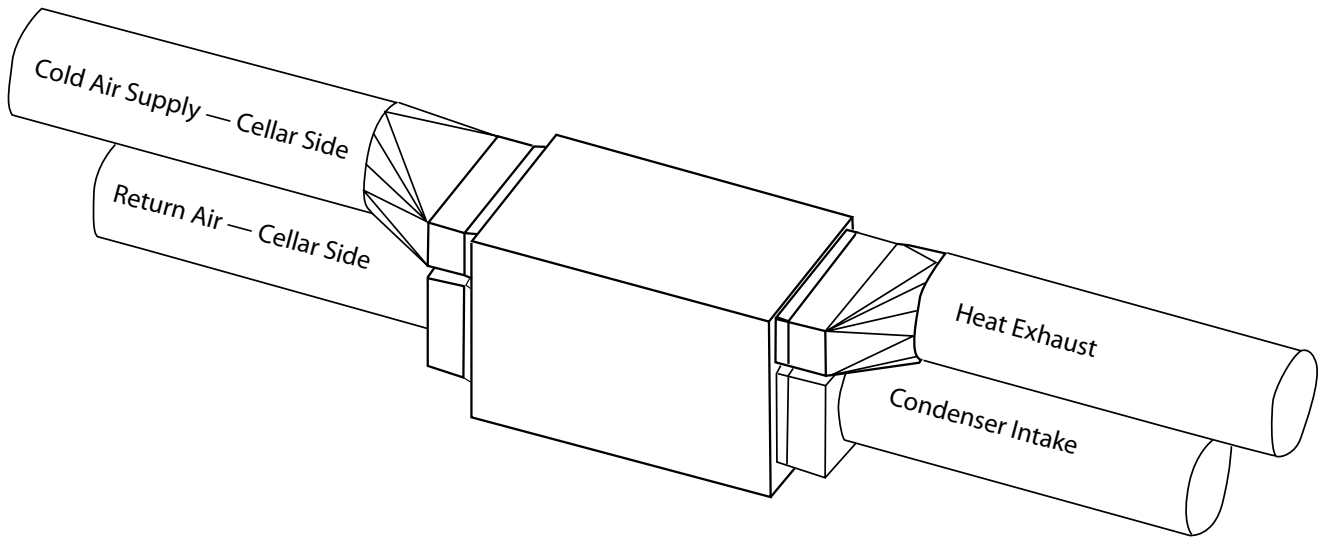

Attic Mounted Unit

It is recommended to use our insulation box and condensate pan for this application.

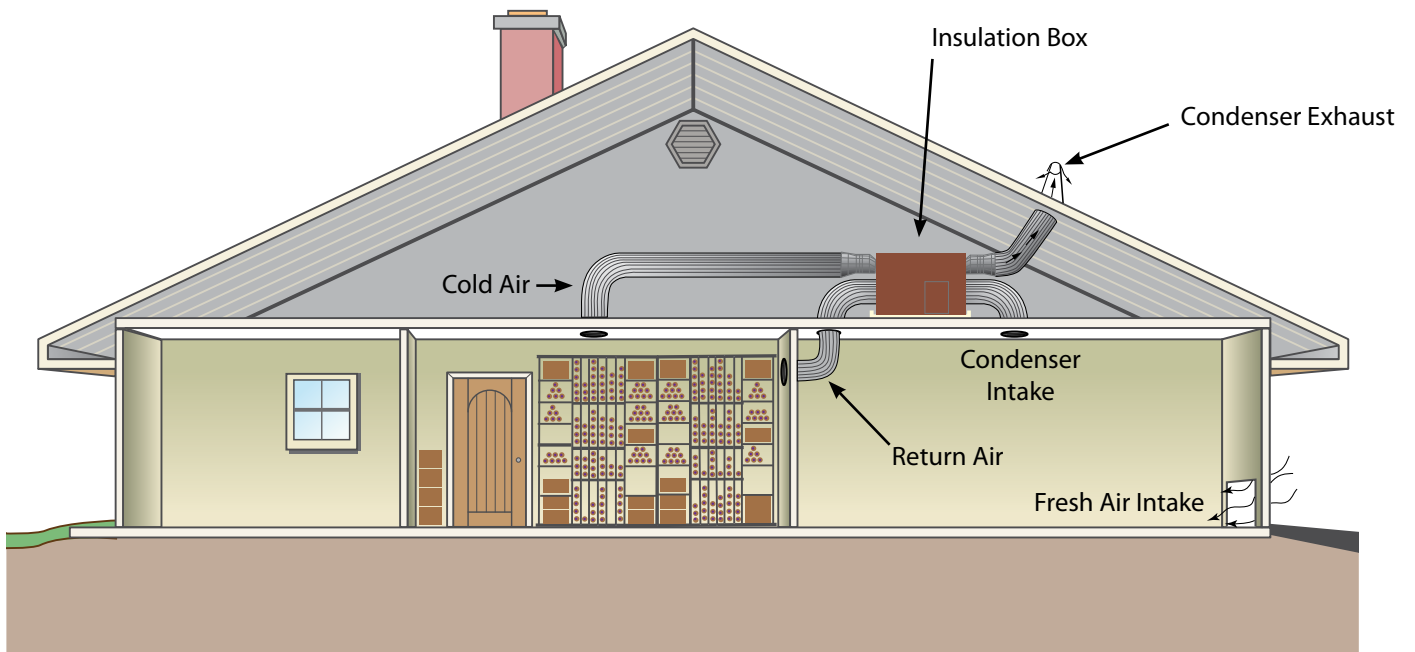

Installing the Duct Plenums

1. Remove the filter grill from the unit by unscrewing the screws that hold it in place.
2. Move the ducting adapters into place
3. Screw the ducting adapters into place using the supplied screws.

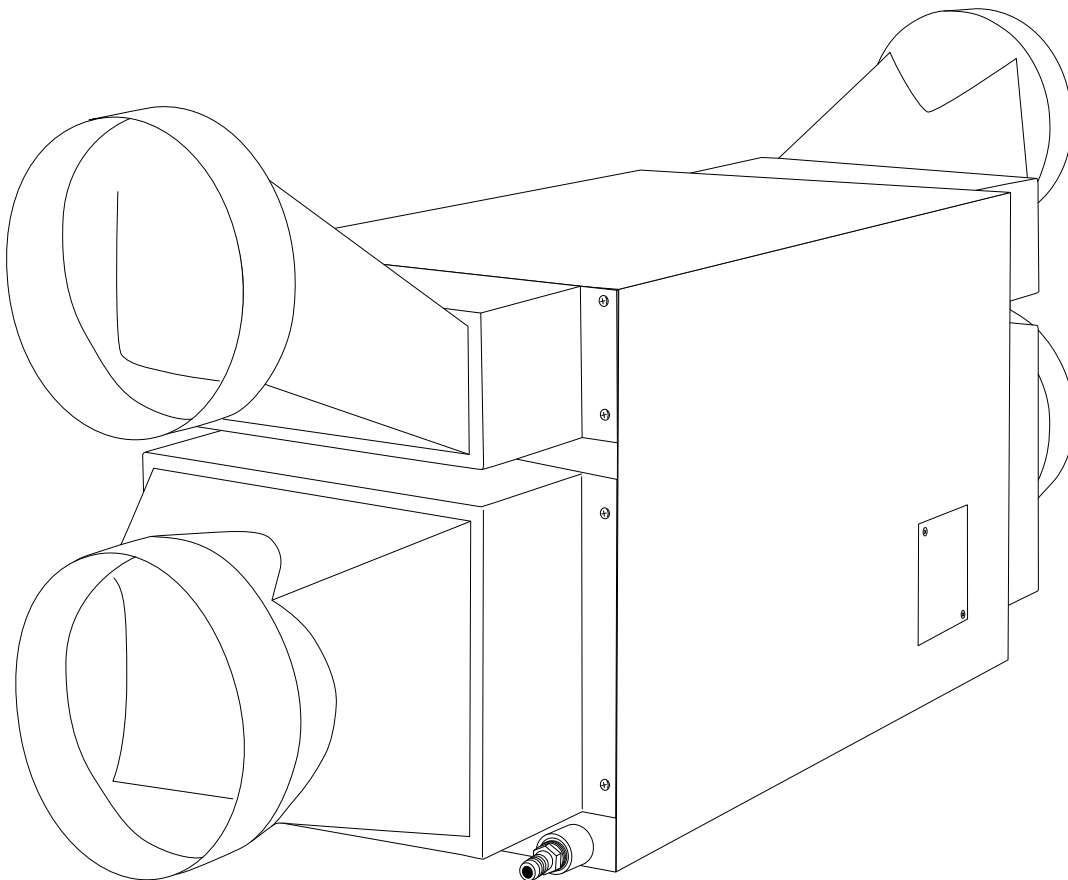
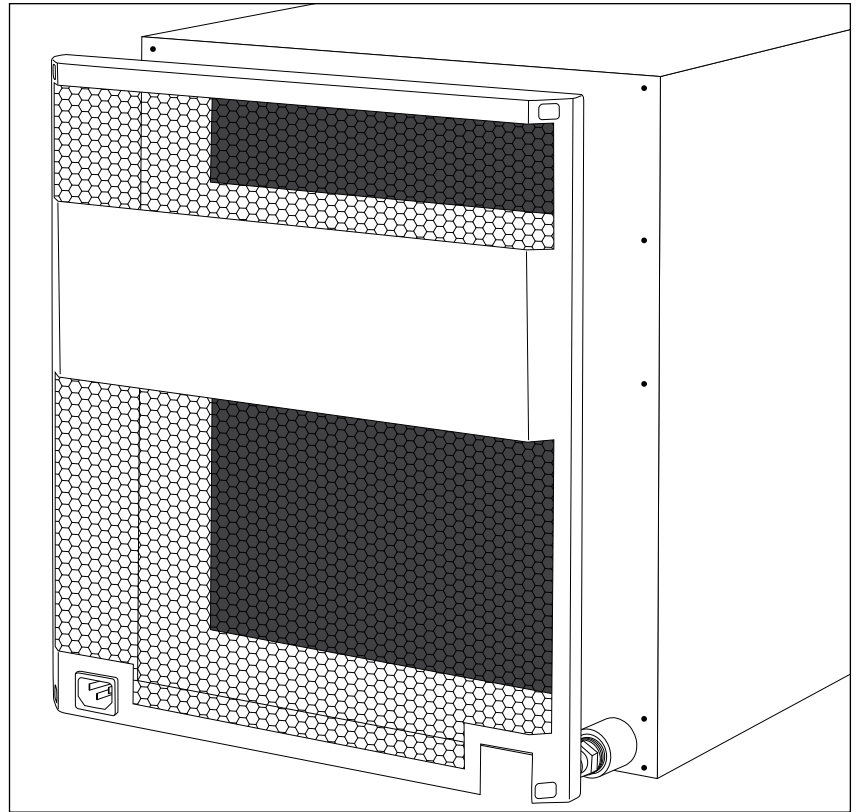

REMOTE CONTROLLER INSTALLATION

If you have a unit with a remote controller (tiR), please review this section.

The controller can be installed up to 50 feet away from the cooling unit, or up to 300 feet away with the extended display wire available from WhisperKOOL.

1. Determine the preferred routing method for the display wire into the controller box.

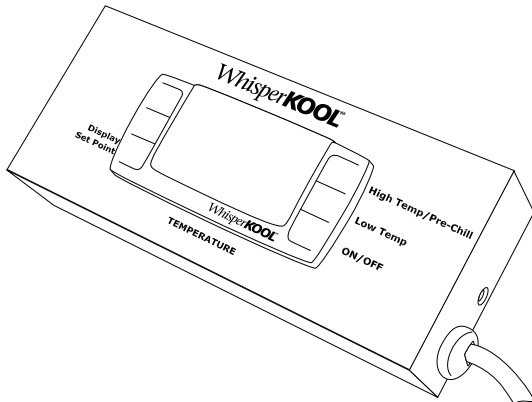

Connection wire in side mount configuration

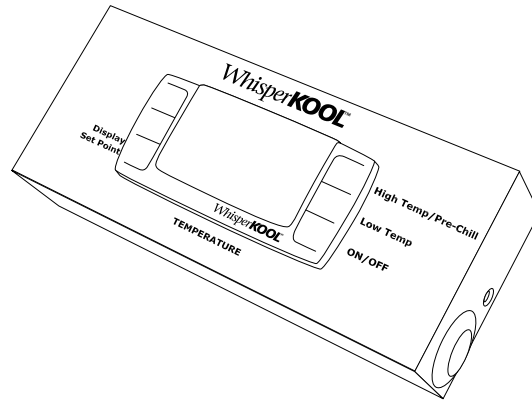

Connection wire in rear mount configuration

2. Attach the display wire as shown below, with the red wire in the upper connection slot and the black wire in the lower slot.

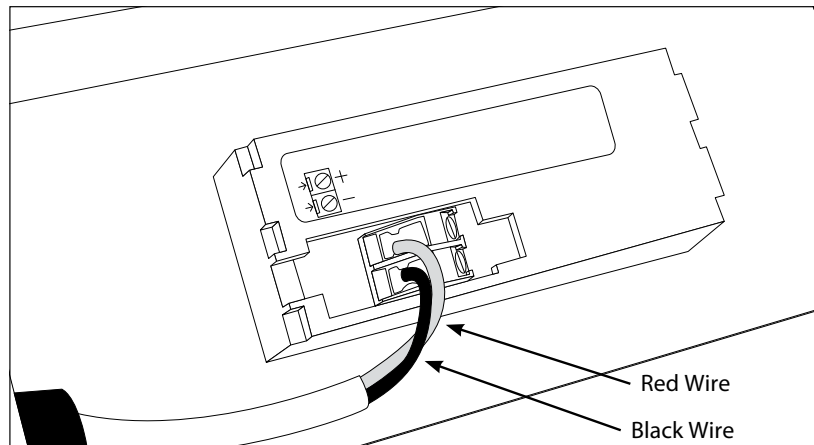

3. Attach the opposite end of the display wire to the circular connector on the front of the unit marked "Display". Twist the connector clockwise to lock it in place.

4. Remove the mounting bracket and secure the bracket to the wall in the desired location. Reattach the controller to the bracket.

Below is an example configuration of the remote controller in a wine cellar.

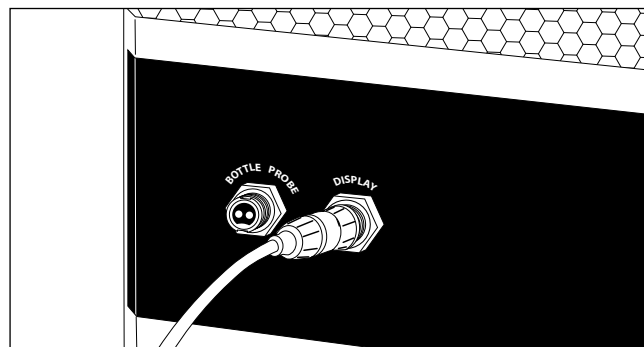
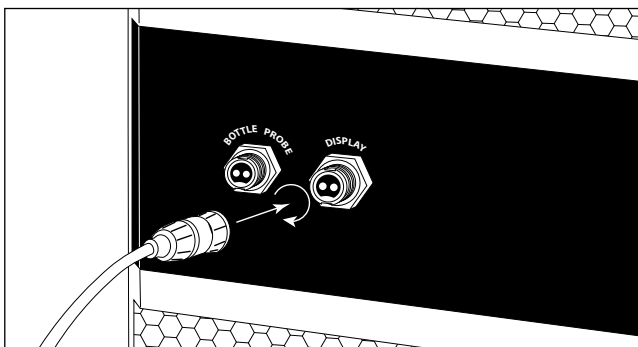

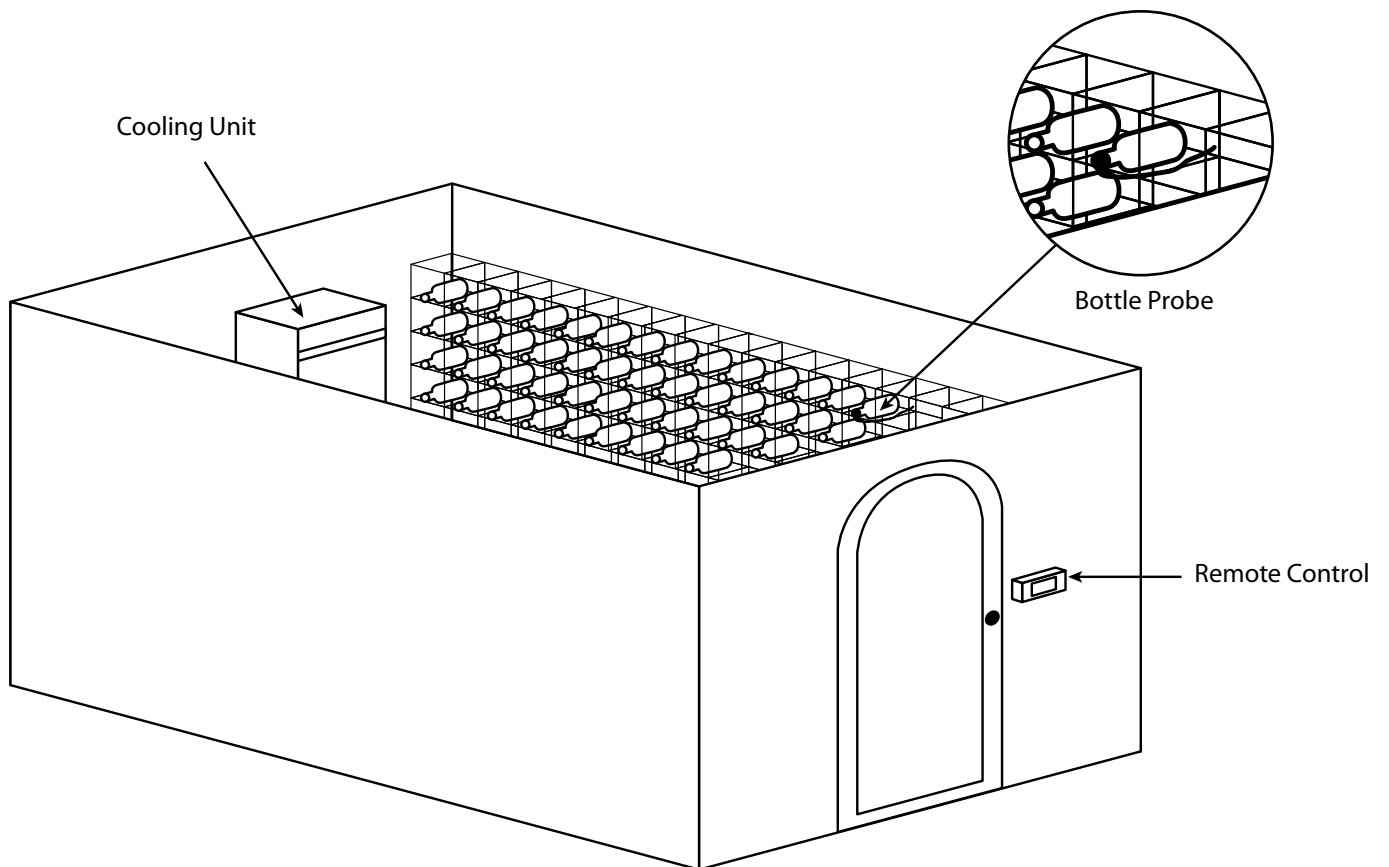
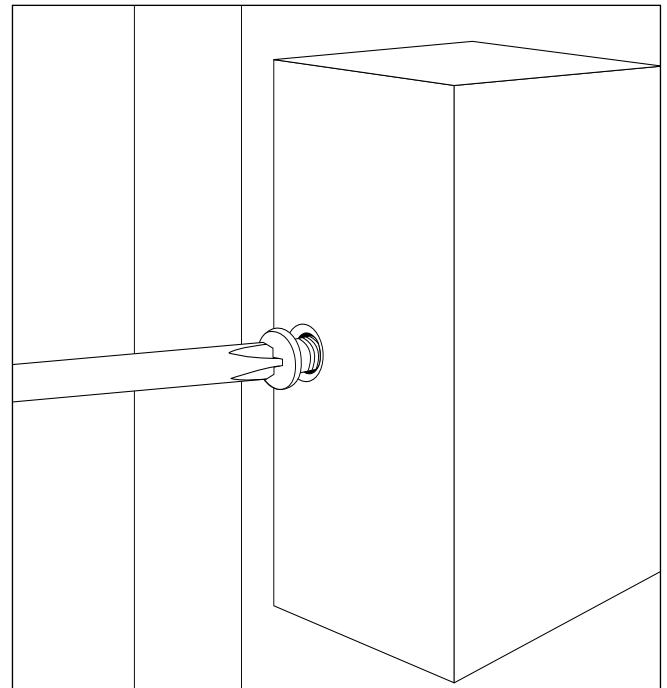
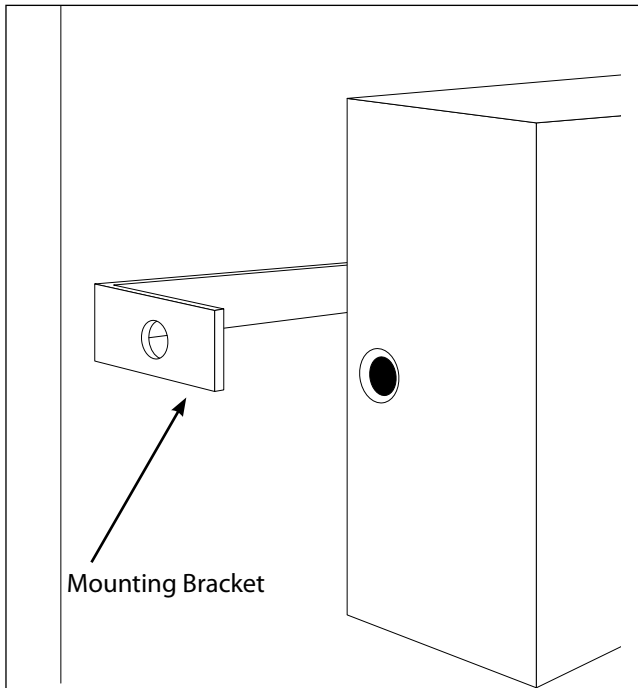

CONDENSATION DRAIN LINE

Condensation Drain Line Tube

The condensation drain line tube is used to remove excess condensation from the unit to a proper discharge location. It is important that the drain line tube is properly connected and used to prevent leakage and other problems associated with excess condensation.

Failure to use the condensation drain line tube will void the warranty on the unit.

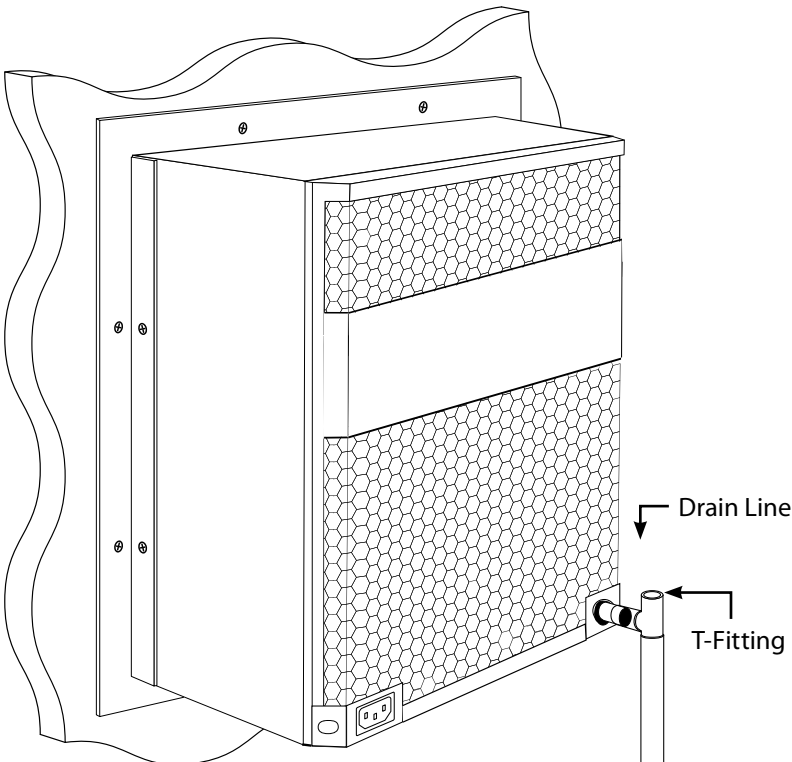

Drain Line

All units come with a drain line for additional removal of excessive condensate. It is mandatory to install the drain line with a "T" fitting. During operation, the cooling unit will strip excess water from the air in order to maintain the proper level of humidity within the cellar. However, in extreme humidity, additional condensate will be removed. The drain line will prevent overflow and leaking by allowing for discharge of the additional condensate.



To prevent mold from growing, allow the drain line to hang above the water line.

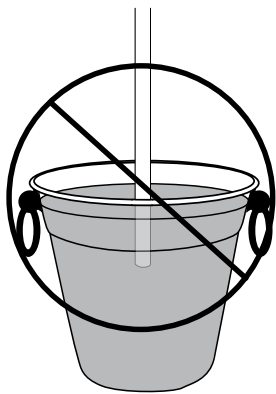

WRONG: Drain line is under water.



LIQUID MEASURING THERMOSTAT SYSTEM

The WhisperKOOL Series cooling units come equipped with a liquid temperature-measuring thermostat. This system incorporates the following advantages:

Self-Calibrating Bottle Probe

The bottle probe contains a sensor chip, which communicates back and forth with the thermostat. This results in a consistent temperature setting and accuracy.

1. Wine should be kept at a very precise, controlled temperature and humidity.
2. By measuring the liquid temperature rather than air, the unit will operate 75–80% of the time.

Setting Up The Bottle Probe:

1. Locate an empty wine bottle.
2. Fill $\frac{3}{4}$ full with room temperature tap water.
3. Place bottle probe securely into bottle as seen in Figure 1.
4. Place bottle with probe level and to the side of the unit in your wine cellar.
5. To assure a consistent temperature, place bottle probe approximately 3 feet away from the air output and not in the flow of the air.
6. Connect the opposite end of the bottle probe wire to the circular connector on the front of the unit marked "Bottle Probe". Twist the connector clockwise to lock it in place as seen in Figure 2.

It is recommended that the bottle be placed in a central location of your wine cellar. Avoid pulling too much on the probe cord. It may become disconnected resulting in limited functionality of the unit.

Note: The thermostat can be set between 50–67°F.

Remember: The WhisperKOOL unit operates based on the temperature of the water. Do not be misled by thermostats reading air temperature. The air temperature in the cellar will be cooler than the liquid temperature of the wine while it is reaching optimum balanced temperature.

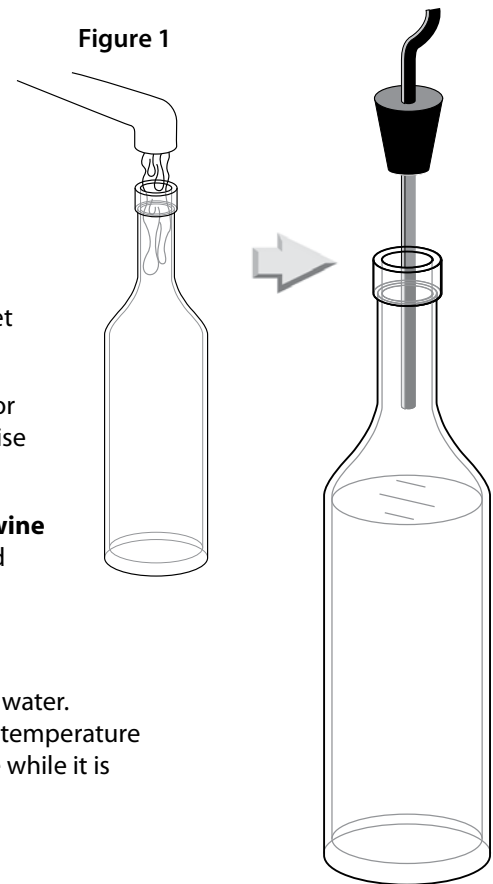
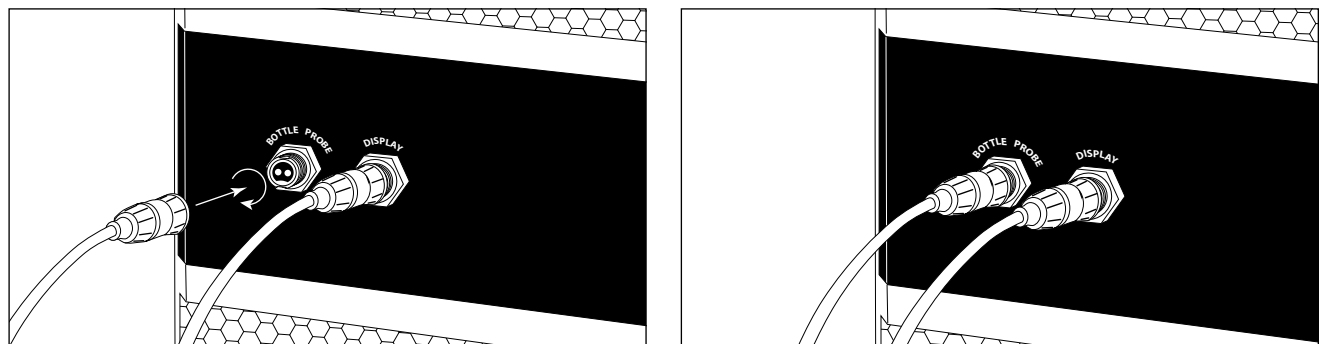

Figure 2



MULTI-SPEED FAN CONTROL

Designed for wine cellars up to 1000 and 2000 cubic feet, the Extreme 3500ti/tiR, 5000ti/tiR and 8000ti/tiR feature multi-speed fans with a high setting for maximum performance in high-temperature (+110°F) environments and a low setting for super-quiet operation.

Fan Speed Selector Switch (Low/Med/High)

The cooling unit fans operate on three speed settings: Low, Medium, and High. For optimum sound and energy efficiency, select the lowest fan speed that will maintain the desired cellar temperature. If the relative humidity is low, a higher fan speed will cause less moisture to be removed during cooling. High speed is recommended for initial cellar cool down, extreme temperature conditions and ducted installations.

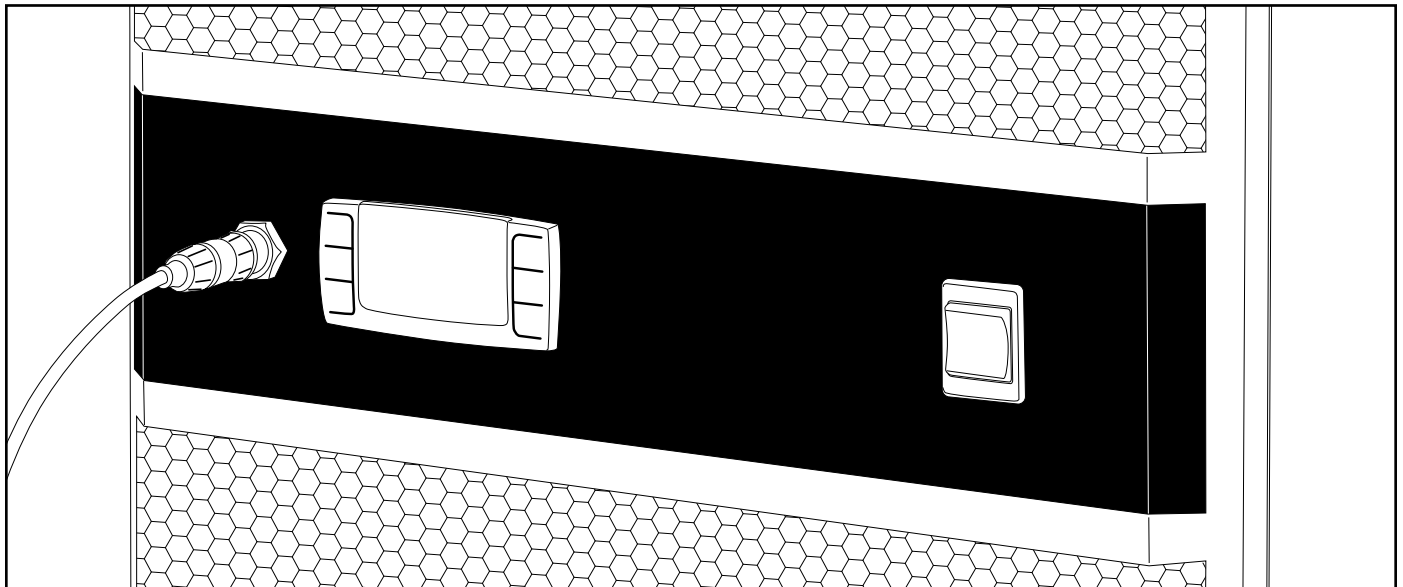

Fan speed selection is determined by the amount of heat that needs to be removed from the cellar and the type of installation (through-the-wall or fully ducted). Fan speed selection is based on the cellar size, insulation factor, door seal and desired wine temperature. When initially installing the unit, set the fan speed to the **High** setting for a quick chill down. Once the wine cellar reaches the desired temperature, a lower fan speed may be selected (for all models except the Extreme 5000tiR FD). In the event that the outdoor temperature rises above 90°F, (when exhausting to the outdoors) a higher fan speed may be required.



Fully ducted units need to be set to the high fan speed position at all times.



All Extreme 5000tiR FD models come from the factory with the fans wired in high speed. The fan speed is not adjustable on these models.

	3500ti 3500tiR			5000ti 5000tiR			8000ti 8000tiR			5000tiR FD		
Speed Selection	Low	Med	High	Low	Med	High	Low	Med	High	Low	Med	High
Air Flow (CFM)	147	180	256	147	180	256	274	318	333	N/A	N/A	256
Sound (dBA* In Cellar / Out of Cellar)	51/51	58/57	66/65	51/51	58/57	66/65	57/57	59/59	60/61	N/A	N/A	66/65
Cooling Capacity (BTU/h)	2374	2514	2688	3099	3453	4126	5140	5606	5760	N/A	N/A	3794

* To get a feeling for decibels, a food blender at 3 ft. is 90 dBA, garbage disposal at 3 ft. is 85 dBA, vacuum cleaner at 10 ft. is 75 dBA, normal speech at 3 ft. is 79 dBA, dishwasher in the next room is 55 dBA, a quiet night is 35 dBA

UNIT OPERATION

Initial Start-Up

When power is applied to the unit, the control will briefly display all symbols, and the Snowflake symbol will be displayed (if unit is calling for cooling). There may be a brief (up to 60 sec.) delay prior to the evaporator fan turning on. When the evaporator fan is activated the Fan symbol will display.

APST (Advance Product Safety Technology) is a temperature control feature for the evaporator fan that comes standard with all WhisperKOOL units. APST ensures that in the possible event of a cooling deficiency, the heat from the indoor fan will not raise the temperature of the wine cellar, which could otherwise have an adverse effect on the wine-aging process.

Set Point

The set point is set from the factory (WhisperKool) at 55F°. It can be adjusted by the customer between 50–70F° in one degree increments.

Cooling Operation

The FON function is an adjustable feature which allows the customer the convenience of reintroducing some of the humidity removed by the fan coil during the cooling process. The FON Function controls the evaporator fan operation once the set point has been reached. When the bottle probe has reached the set point (all units are shipped with the set point of 55°F and a differential of 1°), the compressor and the condenser fan will turn off, but the indoor fan will continue to run for about 5 minutes to re-introduce any moisture from the evaporator coil. All units come with this feature turned off. If low humidity is a problem an increase in this setting will raise the humidity level. The FON function is one of the many Customer Preference Selection features that allow the customer the ability to fine-tune the controls.

Humidity Features

The Fon parameter can be increased to allow the evaporator and condenser fans to run for a longer period of time after the compressor turns off, allowing more moisture to be re-introduced into the wine cellar.

Anti-Short Cycle

The Anti-Short Cycle ensures that the compressor will remain off for a period of three minutes after the unit has reached the set point to allow the pressure in the refrigeration unit to equalize prior to starting the compressor.

Anti-Frost Cycle (defrost)

When the evaporator probe senses a temperature of 26F° for five minutes, the unit will go into Anti-Frost mode. This will shut down the compressor and allow the evaporator and condenser fans to run to evaporate any frost accumulation on the coil. The compressor will remain off until the evaporator coil reaches 40F°, or for a maximum of ten minutes. The unit will then return to normal operation.

Bottle Probe Failure Protection

In the event that a bottle probe should fail, the APST (Advance Product Safety Technology) will automatically transition the refrigeration compressor cycles to a pre-determined time series (based on detailed laboratory testing), which will ensure that the product is kept within the safe range.

Display

The bottle probe temperature is displayed by default. “Def” is displayed during Anti-Frost. The air sensing probe and evaporator probe temperatures can be accessed by pushing the SET button and scrolling through “PB1” (bottle probe), and “PB2” (evaporator probe).

Safety Features

Once the compressor relay is de-energized the controller must wait five minutes before re-energizing the relay. This prevents the compressor from repeatedly turning off and on. If the unit is calling for cooling during this time, the compressor symbol will blink, indicating that cooling is needed but the control is waiting for the Anti-Short cycle delay.

In the event of a faulty bottle probe, the compressor will cycle off for 10 minutes and on for 40 minutes. “E1” will be displayed on the screen.

Alarms









See **Alarm Codes** in the Controller Function chart on page 31.



STANDARD CONTROLLER

If your unit is installed through the wall and does not have a remote keypad you will have the Standard Controller.



Functions

Button/Symbol	Normal Functions
ON/OFF 	The ON/OFF button allows the customer the convenience of turning the refrigeration unit ON or OFF, from the control panel. This feature does not disconnect power from the unit. In order for the power to be shut off from the unit, the power cord must be unplugged from the wall receptacle.
Up and Down Arrows  	Use these buttons to scroll the CPSM (Customer Preference Selection Mode) menu up or down. Displays the highest and lowest temperature sensed by the bottle probe. This feature allows the customer instant access to the recorded data applicable to the bottle probe temperatures, it can be easily reset to reflect current temperatures. <ol style="list-style-type: none"> 1. Press the Up arrow, or the Down arrow once, and the highest or lowest temperature (Hi/Lo) sensed by the bottle probe, will be displayed. 2. To reset the Hi/Lo, press and hold the SET button when the Hi/Lo value is displayed on the display, continue to hold the SET button until "rst" appears on the display and then blinks. This will erase the past recorded temperature data history and start recording from the current time and temperature. Future temperatures displayed will reflect bottle probe temperatures from the reset time and beyond. 3. The Hi/Lo feature should be reset at initial start-up and after the cellar or cabinet has obtained normal operating temperatures, which is generally 55°F.
Cellar PreChill (CPC)  	Activate the CPC feature by pressing the Up arrow for 3–5 seconds until the CPC logo appears on the display. The CPC feature can be terminated by pressing the Up arrow button for 3–5 seconds. The feature will self-terminate after six hours. The CPC feature may be used to pre-chill the cellar prior to loading it with warm product. The feature will shift the set point down to a lower setting of 52°F, for the next 6 hours. After the six-hour time period, the set point will automatically return to the original set point. The CPC feature can be conveniently adjusted to the customer's specific needs, by accessing the CPSM (Customer Preference Select Mode). See CPSM Instructions on page 29.
Energy Reduction (ER) 	The ER feature is activated by pressing the ER button once. The ER symbol will appear on the display. ER feature reduces energy cost by shifting the set point up by four degrees. This allows cooling unit to run for shorter periods of time, resulting in a reduction in energy cost. The ER feature allows for energy savings at any time — during periods of high ambient temperatures, vacations or business travel. To deactivate the ER feature, press the ER button one time, and the ER logo will turn off. The ER feature can be conveniently adjusted to the customer's specific needs. See CPSM Instructions on page 31.
Anti-Frost  AUX	The Anti-Frost cycle is automatically activated when the evaporator has reached a sustained low temp of 26°F for a period of five minutes. During this cycle the compressor and condenser fans will turn off while the evaporator fans continue to run. Once the temperature of the evaporator gets back up to 40°F the cycle will deactivate and the unit will revert back to normal operating conditions. At the beginning of the cycle the AUX symbol will display and the  symbol is illuminated during the anti-frost cycle.

Button/Symbol	Normal Functions						
SET 	<p>Press the SET button once and it will display the set point. After approximately 5 seconds, the display will return to normal operation and display the bottle probe temperature.</p> <table border="1"> <tr> <td>Change the Set Point</td> <td>Press and hold the SET button for 3–5 seconds until the set point is displayed and the °F symbol blinks. Press the UP or Down arrows to select a new set point. Press the SET button once and the set point numbers and the °F on the display will blink to confirm the new setting.</td> </tr> <tr> <td>Reset Temperature History</td> <td>Press and hold the SET button during the display of the Hi/Lo (temperature data history). Hold button until “rst” blinks on display, erasing the current time and temperature data.</td> </tr> <tr> <td>CPSM</td> <td>Press the SET and the Down arrow buttons simultaneously, for 10–15 seconds to enter CPSM (Customer Preference Selection Mode).</td> </tr> </table>	Change the Set Point	Press and hold the SET button for 3–5 seconds until the set point is displayed and the °F symbol blinks. Press the UP or Down arrows to select a new set point. Press the SET button once and the set point numbers and the °F on the display will blink to confirm the new setting.	Reset Temperature History	Press and hold the SET button during the display of the Hi/Lo (temperature data history). Hold button until “rst” blinks on display, erasing the current time and temperature data.	CPSM	Press the SET and the Down arrow buttons simultaneously, for 10–15 seconds to enter CPSM (Customer Preference Selection Mode).
Change the Set Point	Press and hold the SET button for 3–5 seconds until the set point is displayed and the °F symbol blinks. Press the UP or Down arrows to select a new set point. Press the SET button once and the set point numbers and the °F on the display will blink to confirm the new setting.						
Reset Temperature History	Press and hold the SET button during the display of the Hi/Lo (temperature data history). Hold button until “rst” blinks on display, erasing the current time and temperature data.						
CPSM	Press the SET and the Down arrow buttons simultaneously, for 10–15 seconds to enter CPSM (Customer Preference Selection Mode).						
Alarm 	The Alarm symbol is shown when the unit encounters an issue that needs attention, the displayed alarm codes are explained below.						

Alarm Codes

Message	Cause	Solution
“P1”	Bottle probe is unplugged	Attach bottle probe to unit
	Faulty bottle probe connection	1. Check bottle probe attachment at circular connector 2. Check bottle probe connection at the back of controller
	Defective Bottle Probe	Replace the bottle probe
“P2”	Faulty Evaporator Probe Connection	Check evaporator probe connection at green terminal block on the back of controller
	Defective Evaporator Probe	Replace the evaporator probe
“HA”	Defective Bottle Probe	Replace the bottle probe
“LA”	The bottle probe is sensing a temperature that is 4° below the set point	Allow the room to warm up which will increase the temperature of the wine
	Defective Bottle Probe	Replace the bottle probe
“POF”	The keypad is locked	Hold Up and Down arrow buttons for 3–5 seconds to disable. “PON” will display.

CPSM (Customer Preference Selection Mode)

Press and hold the SET and Down Arrow buttons for 10–15 seconds to enter the CPSM menu.

Fon <i>Humidity Management/Enhancement</i>	This parameter is set to 0 from the factory, which should provide adequate relative humidity for the cellar. An increase in this parameter will increase the Humidity Enhancement (%RH). Adjustments should be made in increments of 5, with a maximum of 15 and a minimum of 0. After any adjustment to Humidity Enhancement, wait a minimum of three days before making any additional adjustments. This will allow the cellar sufficient time to acclimate to the new setting.
Fof	This parameter is normally set at 15. This parameter should not be adjusted, as it simply provides an OFF cycle time for the fan, during the compressor OFF cycle.
CCS	<i>Cellar Pre-Chill Set Point.</i> This parameter is set at 52°F, but can be adjusted to a set point between 50–67°F.
CCT	<i>Cellar Pre-Chill Duration.</i> This parameter is set to 6 hours, but can be adjusted to a set point between 0–23.5 hours.
Con/Cof	<i>Compressor On time (Con) and Off time (Cof) with a P1 Alarm.</i> These parameters are set at Con 40 min/Cof 10 min. In the event of a P1 Alarm, the compressor/refrigeration system automatically starts a predetermined ON/OFF cycle, which is controlled by the Con and Cof parameters. These parameters can be adjusted to maintain the desired bottle temperature.
Hes	<i>Differential for Energy Reduction.</i> During the Energy Reduction mode, this parameter is set at 4°F above the set point. A decrease in this setting will lower the set point and an increase in this feature will raise the set point.

Standard Controller Wiring Schematic

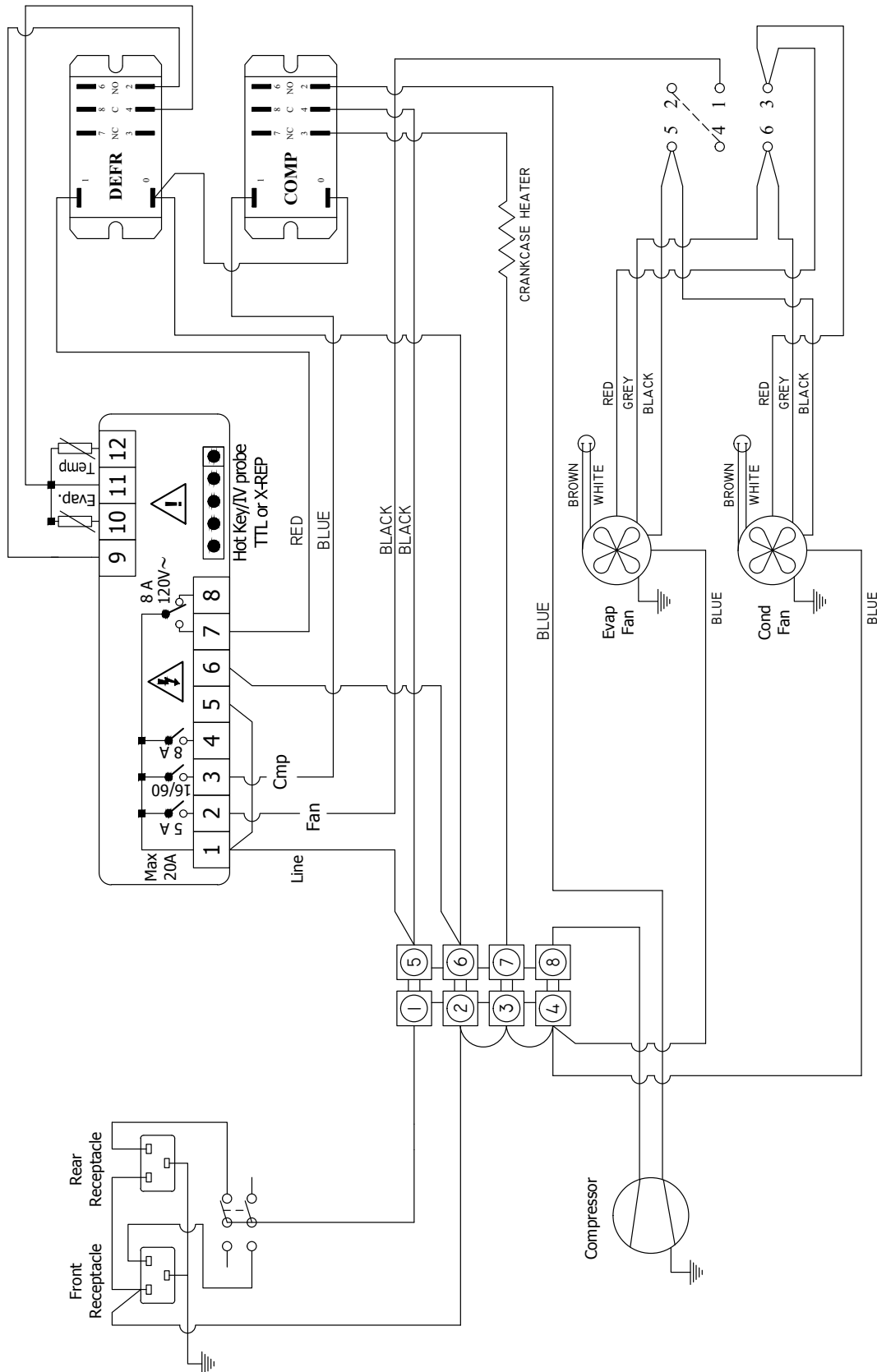







REMOTE CONTROLLER

If your unit has a remote keypad then you will have the Remote Controller.



TEMPERATURE

Functions

Button/Symbol	Normal Functions						
<p>ON/OFF</p> 	<p>The ON/OFF button allows the customer the convenience of turning the refrigeration unit ON or OFF, from the control panel. This feature does not disconnect power from the unit. In order for the power to be shut off from the unit, the power cord must be unplugged from the wall receptacle.</p>						
<p>Up and Down Arrows</p>  	<p>Use these buttons to scroll the CPSM (Customer Preference Selection Mode) menu up or down. Displays the highest and lowest temperature sensed by the bottle probe. This feature allows the customer instant access to the recorded data applicable to the bottle probe temperatures, it can be easily reset to reflect current temperatures.</p> <ol style="list-style-type: none"> 1. Press the Up arrow, or the Down arrow once, and the highest or lowest temperature (Hi/Lo) sensed by the bottle probe, will be displayed. 2. To reset the Hi/Lo, press and hold the SET button when the Hi/Lo value is displayed on the display, continue to hold the SET button until "rst" appears on the display and then blinks. This will erase the past recorded temperature data history and start recording from the current time and temperature. Future temperatures displayed will reflect bottle probe temperatures from the reset time and beyond. 3. The Hi/Lo feature should be reset at initial start-up and after the cellar or cabinet has obtained normal operating temperatures, which is generally 55°F. 						
<p>Cellar PreChill (CPC)</p>  	<p>Activate the CPC feature by pressing the Up arrow for 3–5 seconds until the CPC logo appears on the display. The CPC feature can be terminated by pressing the Up arrow button for 3–5 seconds. The feature will self-terminate after six hours</p> <p>The CPC feature may be used to pre-chill the cellar prior to loading it with warm product. The feature will shift the set point down to a lower setting of 52°F, for the next 6 hours. After the six-hour time period, the set point will automatically return to the original set point.</p> <p>The CPC feature can be conveniently adjusted to the customer's specific needs, by accessing the CPSM (Customer Preference Select Mode). See CPSM Instructions on page 29.</p>						
<p>SET</p> 	<p>Press the SET button once and it will display the set point. After approximately 5 seconds, the display will return to normal operation and display the bottle probe temperature.</p> <table border="1" data-bbox="414 1564 1518 1869"> <tbody> <tr> <td>Change the Set Point</td> <td>Press and hold the SET button for 3–5 seconds until the set point is displayed and the °F symbol blinks. Press the UP or Down arrows to select a new set point. Press the SET button once and the set point numbers and the °F on the display will blink to confirm the new setting.</td> </tr> <tr> <td>Reset Temperature History</td> <td>Press and hold the SET button during the display of the Hi/Lo (temperature data history). Hold button until "rst" blinks on display, erasing the current time and temperature data.</td> </tr> <tr> <td>CPSM</td> <td>Press the SET and the Down arrow buttons simultaneously, for 10–15 seconds to enter CPSM (Customer Preference Selection Mode).</td> </tr> </tbody> </table>	Change the Set Point	Press and hold the SET button for 3–5 seconds until the set point is displayed and the °F symbol blinks. Press the UP or Down arrows to select a new set point. Press the SET button once and the set point numbers and the °F on the display will blink to confirm the new setting.	Reset Temperature History	Press and hold the SET button during the display of the Hi/Lo (temperature data history). Hold button until "rst" blinks on display, erasing the current time and temperature data.	CPSM	Press the SET and the Down arrow buttons simultaneously, for 10–15 seconds to enter CPSM (Customer Preference Selection Mode).
Change the Set Point	Press and hold the SET button for 3–5 seconds until the set point is displayed and the °F symbol blinks. Press the UP or Down arrows to select a new set point. Press the SET button once and the set point numbers and the °F on the display will blink to confirm the new setting.						
Reset Temperature History	Press and hold the SET button during the display of the Hi/Lo (temperature data history). Hold button until "rst" blinks on display, erasing the current time and temperature data.						
CPSM	Press the SET and the Down arrow buttons simultaneously, for 10–15 seconds to enter CPSM (Customer Preference Selection Mode).						
<p>Alarm</p> 	<p>The Alarm symbol is shown when the unit encounters an issue that needs attention, the displayed alarm codes are explained on page 34.</p>						

Alarm Codes

Message	Cause	Solution
"P1"	Bottle probe is unplugged	Attach bottle probe to unit
	Faulty bottle probe connection	1. Check bottle probe attachment at circular connector 2. Check bottle probe connection at the back of controller
	Defective Bottle Probe	Replace the bottle probe
"P2"	Faulty Evaporator Probe Connection	Check evaporator probe connection at green terminal block on the back of controller
	Defective Evaporator Probe	Replace the evaporator probe
"HA"	Defective Bottle Probe	Replace the bottle probe
"LA"	The bottle probe is sensing a temperature that is 4° below the set point	Allow the room to warm up which will increase the temperature of the wine
	Defective Bottle Probe	Replace the bottle probe
"POF"	The keypad is locked	Hold Up and Down arrow buttons for 3–5 seconds to disable. "PON" will display.

CPSM (Customer Preference Selection Mode)

Press and hold the SET and Down Arrow buttons for 10–15 seconds to enter the CPSM menu.

Fon <i>Humidity Management/Enhancement</i>	This parameter is set to 0 from the factory, which should provide adequate relative humidity for the cellar. An increase in this parameter will increase the Humidity Enhancement (%RH). Adjustments should be made in increments of 5, with a maximum of 15 and a minimum of 0. After any adjustment to Humidity Enhancement, wait a minimum of three days before making any additional adjustments. This will allow the cellar sufficient time to acclimate to the new setting.
Fof	This parameter is normally set at 15. This parameter should not be adjusted, as it simply provides an OFF cycle time for the fan, during the compressor OFF cycle.
CCT	<i>Cellar Pre-Chill Duration.</i> This parameter is set to 6 hours, but can be adjusted to a set point between 0–23.5 hours.
Con/Cof	<i>Compressor On time (Con) and Off time (Cof) with a P1 Alarm.</i> These parameters are set at Con 40 min/Cof 10 min. In the event of a P1 Alarm, the compressor/refrigeration system automatically starts a predetermined ON/OFF cycle, which is controlled by the Con and Cof parameters. These parameters can be adjusted to maintain the desired bottle temperature.

Remote Controller Wiring Schematic

For Models:
3500tiR
3500tiR FD
5000tiR
8000tiR
8000tiR FD

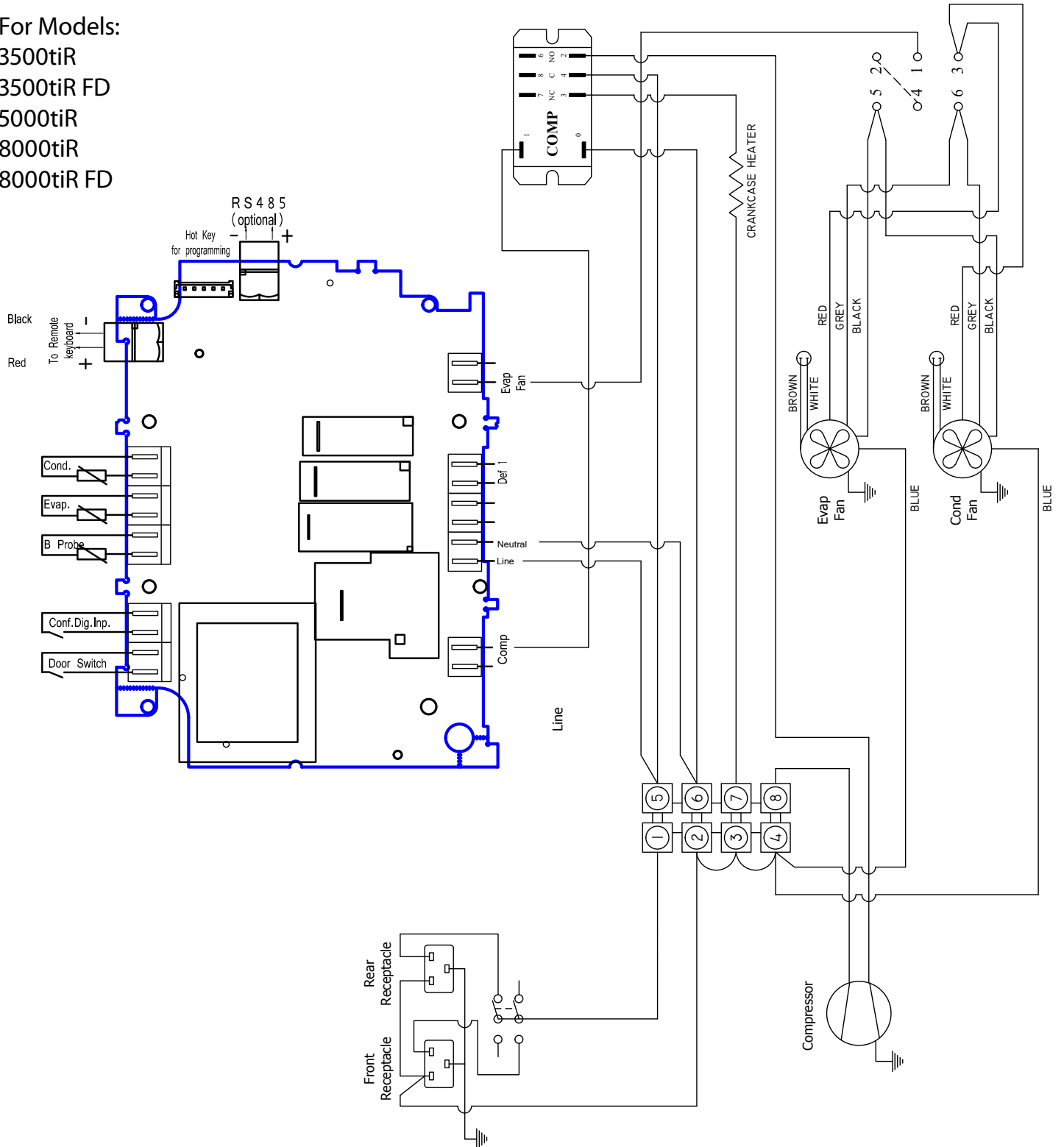

Extreme 500tiR FD Wiring Schematic

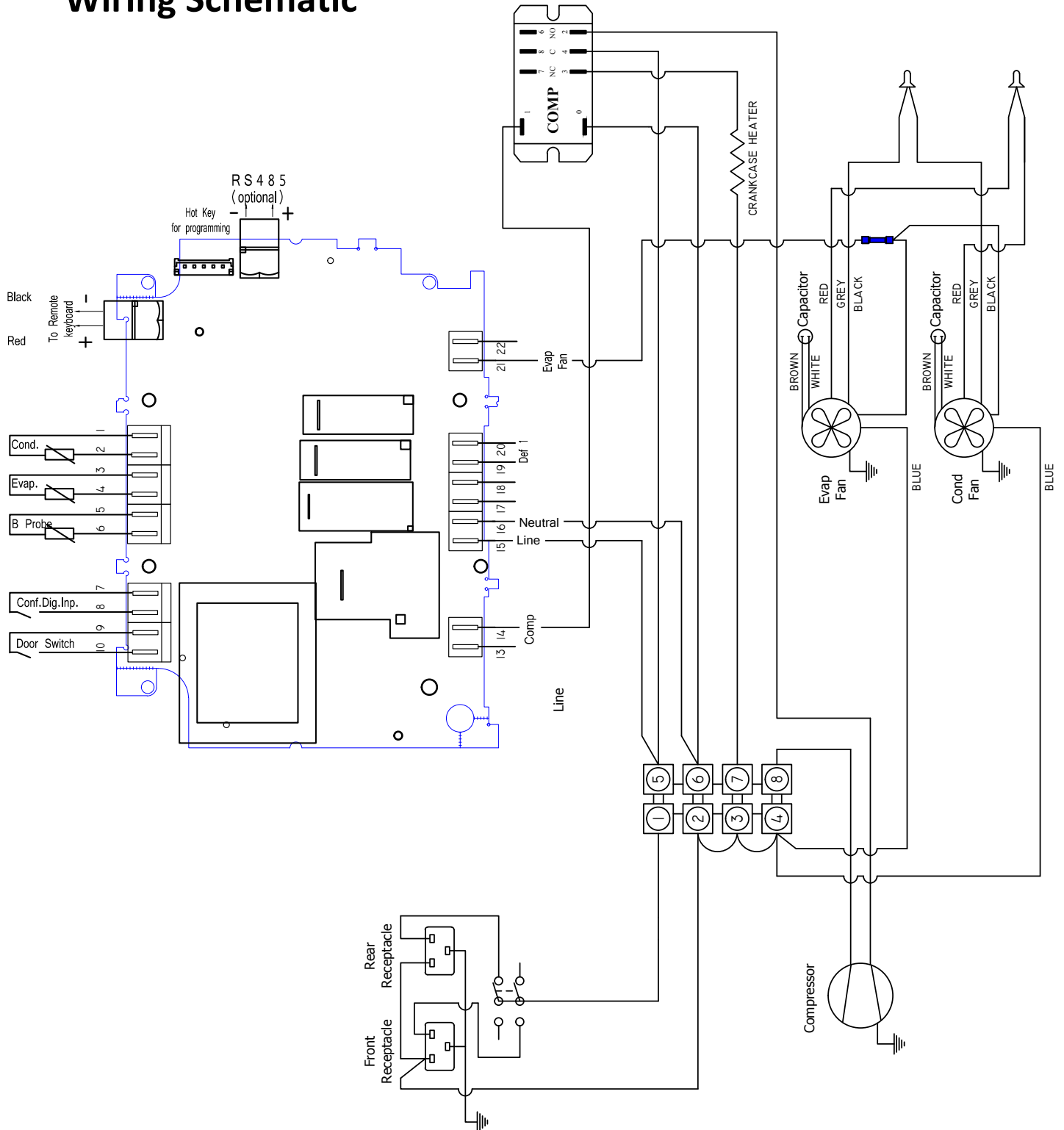

TROUBLESHOOTING GUIDE

Unit Has Ice Forming on the Evaporator	
Possible Cause	Solution
Evaporator coil is dirty	Clean coil with a vacuum If coil is very dirty, use a spray bottle with a small amount of liquid dish washing detergent. Spray coil, let set for 5 min, then flush with fresh water
Something is blocking the supply and/or return air	Remove blockage
Evaporator fan is not turning on	Call a service tech to troubleshoot
Unit has not gone through its Anti-Frost sequence	Check for ice in the depth of the coil. Melt with blow drier until coil is warm to the touch. Soak up water with a towel
Unit continues to ice	Observe ice formation pattern. If only part way up the coil face, unit could be low on refrigerant. If all the way up, the coil may be dirty or airflow is blocked
Unit Does Not Run/Power Up	
Possible Cause	Solution
Unit is not plugged in	Make sure the unit is plugged into an outlet
Power switch not on	Turn unit on by pressing the power button on the control
Line voltage is incorrect rating for unit	Check line voltage to make sure there is 110V/120V
Bottle at set point	Lower set point
Thermostat not calling for cooling	Lower set point
Power select switch in wrong position	See page 12 for correct switch position
Faulty thermostat or wiring	Call Customer Service at 1-800-343-9463
Cellar Temperature is too Warm	
Possible Cause	Solution
Temperature of the room unit is exhausting to has exceeded 85°F	Intake temperature needs to drop below 110°F
Unit is undersized for the cellar	Order correct size unit
Something is blocking the supply and/or return air, on evaporator or condenser side of the unit	Remove air flow obstruction
Unit is mounted too low in the cellar	Re-locate unit so the distance from the ceiling and top of the unit is no more than 18"
One or more of the fans is not turning on	Call Customer Service at 1-800-343-9463
Compressor is not turning on	Call Customer Service at 1-800-343-9463
Compressor keeps cycling on overload	Make sure all fans are working and there is no airflow obstruction
Poor seal around door	Make sure there are no air gaps around the door. If door seal is damaged, replace it
Controller set too high	Lower the set point
Evaporator coil is frosted or iced up	Observe ice formation pattern. If only part way up the coil face, unit could be low on refrigerant. If so, call Customer Service at 1-800-343-9463
System Runs Constantly	
Possible Cause	Solution
Leaky door seal or poorly insulated cellar	Fix leaky door seal and insulate cellar in accordance with this manual (page 10).

Unit Leaks Water	
Possible Cause	Solution
Unit is level	System should have a 2 degree pitch towards the exhaust side
Drain line clogged or kinked	Check drain line to make sure water can flow freely
Drain is clogged preventing water from escaping	Disconnect drain and clear out, open access door and check drain for blockage
Drain line does not have a downward slope	Fix drain line so there is a downward slope from the unit to the drain
Coil is iced causing drain pan ice and overflowing water.	Melt ice with blow drier. Soak up with a towel
Unit Runs But Does Not Cool	
Possible Cause	Solution
Lack of air flow	Make sure fan is unobstructed and coil is clean
Compressor not running	Call Customer Service at 1-800-343-9463
Unit undersized	Call Customer Service at 1-800-343-9463
Compressor is overheating	Shut unit off for 1 hour to allow compressor to cool. Turn back on and check for cooler air to flow out. If compressor runs, check for and clean condenser coil as a possible cause of compressor overheating. If problem repeats, call Customer Service at 1-800-343-9463
Evaporator Fan Runs But Compressor Does Not	
Possible Cause	Solution
Running an Anti-Frost cycle	Check evaporator coil temperature
Compressor and/or starting components faulty	Call Customer Service at 1-800-343-9463
Fon parameter has been increased, allowing fans to run after the compressor turns off	Lower the Fon parameter
Compressor may have overheated	Shut unit off for 1 hour to allow compressor to cool. Turn back on and check for cooler air to flow out. If compressor runs, check for and clean condenser coil as a possible cause of compressor overheating. If problem repeats, call Customer Service at 1-800-343-9463
Compressor Runs But Evaporator Fan Does Not	
Possible Cause	Solution
Faulty fan motor	Call Customer Service at 1-800-343-9463
Faulty controller	Call Customer Service at 1-800-343-9463
Compressor Short Cycles	
Possible Cause	Solution
Evaporator blows on bottle probe	Move bottle probe to a more central location
Unit low on refrigerant charge	Call Customer Service at 1-800-343-9463
Condensing fan motor/capacitor faulty	Call Customer Service at 1-800-343-9463
Compressor and/or starting components faulty	Call Customer Service at 1-800-343-9463
Humidity in Cellar too Low	
Possible Cause	Solution
Not enough moisture	Install something that makes humidity like a water fountain

MAINTENANCE SCHEDULE

Monthly	<ol style="list-style-type: none">1. Check filters2. Check for unusual noise or vibration3. Check drain line to see if it is above the waterline when draining into a vessel
Quarterly	<ol style="list-style-type: none">1. Clean Filters2. Replace Filters on ducted units3. Open access door and add chlorine tablets to drip tray. (3500ti/tiR & 5000ti/tiR only)
Annually	<ol style="list-style-type: none">1. Replace filters if worn or plugged beyond cleaning.2. Use a vacuum with brush attachment to clean coils. Be careful not to crush coil fins when cleaning.3. Inspect for corrosion.4. Check wiring connections and integrity of cords.5. Examine duct work for cracks or possible leaks.6. Pour a 50/50 bleach solution into the drain line every spring.

TECHNICAL ASSISTANCE

WhisperKOOL Customer Service is available Monday through Friday from 6:00 a.m. to 4:00 p.m. Pacific Standard Time.

The appointed customer service representative will be able to assist you with your questions and warranty information more effectively if you provide them with the following:

The model and serial number of your WhisperKOOL unit.

Location of unit and installation details, such as ventilation, ducting, construction of your wine cellar, and room size. Photos of the cellar and installation location may be needed.

Contact WhisperKOOL Customer Service

1738 E. Alpine Ave
Stockton, CA 95205
www.WhisperKOOL.com

E-mail: support@whisperkool.com

Phone: 209-466-9463

US Toll Free: 1-800-343-9463

Fax: 209-466-4606

ACCESSORIES FOR COOLING UNITS

WhisperKOOL offers accessories to enhance and customize your wine cooling unit.

Exterior Grille

Protects the unit from the weather elements when placed on the exhaust side.

- Small Exterior Grille (used for Extreme 3500ti, 3500ti, 5000ti & 5000tiR)
- Large Exterior Grille (used for Extreme 8000ti & 8000tiR)

Condensate Pump Kit

The condensate pump kit is designed as an automatic condensate removal pump for water dripping out of our cooling units' drain line. The pump is controlled by a float/switch mechanism that turns the pump on when approximately 2¼" of water collects in the tank, and automatically switches off when the tank drains to approximately 1¼". The condensate pump kit allows the excess condensate to be pumped up to 20 feet away from the unit.

Extreme Ducting Kit

This kit allows either side of the unit to be ducted. Duct the cold air through a vent into the cellar, duct the hot exhaust air out of the home. This option allows for total installation flexibility.

Note: Flex or rigid ductwork is not included.

Accessories can be purchased at www.whisperkool.com

**WhisperKOOL Product Terms and Conditions
Including Product Limited Warranty And Product Installation Requirements
For WhisperKOOL Extreme Series**

ATTENTION: PLEASE READ THESE TERMS OF USE CAREFULLY BEFORE INSTALLING YOUR WHISPERKOOL COOLING SYSTEM. INSTALLING YOUR WHISPERKOOL COOLING SYSTEM INDICATES THAT YOU ACCEPT AND AGREE TO EACH OF THE TERMS AND CONDITIONS SET FORTH HEREIN ("TERMS OF USE"). IF YOU DO NOT ACCEPT THESE TERMS OF USE, YOU RISK VOIDING YOUR WARRANTY AND ASSUMING ADDITIONAL REPAIR AND REPLACEMENT COSTS.

1. Purchase of a WhisperKOOL Cooling System assumes that the Purchaser ("End User") fully accepts and agrees to the Terms and Conditions set forth in this document. The Terms and Conditions of Sale and Owner's Manual are shipped with each unit and, if another copy is needed, replacement copies can be downloaded from the company website (whisperkool.com) or by contacting WhisperKOOL directly for a new copy. WhisperKOOL reserves the right, in its sole discretion, to change its Terms and Conditions at any time, for any reason, without notice.

2. WhisperKOOL Product Limited Warranty:

A. Two (2) Year Limited Warranty: For the period of TWO (2) YEARS (the "Limited Warranty Period") from the date of original sale of a Product by WhisperKOOL, if a WhisperKOOL Product is found to be defective in material or workmanship after undergoing WhisperKOOL's Customer Service troubleshooting, then, subject to the WhisperKOOL Product Limited Warranty Limitations and Exclusions as well as the other Terms and Conditions stated herein, WhisperKOOL will do the following, as appropriate, for the end user ("End User") who has installed and is actually using the Product, with regard to LABOR, PARTS and FREIGHT:

1. **LABOR** — Repair or replace (at WhisperKOOL's sole option) the Product to the End User; and
2. **PARTS** — Supply to the End User, new or rebuilt replacement parts for the Product in exchange for the return of defective parts; and
3. **FREIGHT** — Cover normal ground freight charges for parts, and, in the event the Product is not repairable in the field, cover normal ground freight charges (within the continental United States) for the repair or replacement of the Product.

B. Five (5) Year Compressor Limited Warranty: WhisperKOOL Products' compressor only will be covered for five (5) years from date of purchase. Labor and freight of the compressor is the End Users responsibility.

C. Product Warranty Limitations and Exclusions:

1. This limited warranty does not cover cosmetic damage caused during installation, damage due to acts of God, commercial use, accident, misuse, abuse, negligence, or modification to any part of the Product. Delivery and installation of the Product, any additional parts required, as well as removal of the Product if warranty work is required, are all at the sole cost, risk and obligation of the End User.
2. This limited warranty does not cover damage due to improper installation or operation or lack of proper maintenance of the Product, connection of the Product to improper voltage supply, or attempted repair of the Product by anyone other than a technician approved by WhisperKOOL to service the Product.
3. This limited warranty does not cover any Product sold "AS IS" or "WITH ALL FAULTS."
4. Product that has been replaced during warranty period does not extend the warranty period past the original date of purchase.
5. (5) This limited warranty is valid only in the continental United States. Sales elsewhere are excluded from this warranty.
6. Proof of purchase of the Product in the form of a bill of sale, receipted invoice or serial number, which is evidence that the Product is within the Limited Warranty Period, must be presented by the End User to WhisperKOOL in order to obtain limited warranty service.
7. This limited warranty is void if the factory applied serial number has been altered or removed from the Product.

8. This limited warranty is voided if installed in an enclosure of insufficient design that does not follow the Product installation requirements stated herein and in the Owner's Manual.
9. Removing the rivets from the Product's unit housing without prior authorization from WhisperKOOL voids this limited warranty.
10. The End User must first contact WhisperKOOL Customer Service by telephone (at 1-800-343-9463) prior to attempting service on any Product still under the limited warranty; else the limited warranty is voided.
11. This limited warranty does not cover Product being concealed by, but not limited to; vegetation, fabric, shelving, mud, snow, or dirt. Product must not be painted or limited warranty will be void.
12. This limited warranty does not cover exposure to corroding environments such as, but not limited to; petroleum and gasoline products, cleaning solvents, caustic pool chemicals, and marine air.
13. This limited warranty does not cover any cause not relating to Product defect.
14. THE REPAIR OR REPLACEMENT OF THE PRODUCT AS PROVIDED UNDER THIS LIMITED WARRANTY IS THE EXCLUSIVE REMEDY OF YOU, THE END USER, AS WELL AS ANYONE ELSE IN THE CHAIN OF TITLE OF THE PRODUCT, DOES NOT START A NEW LIMITED WARRANTY TIME PERIOD, AND IS IN LIEU OF ALL OTHER WARRANTIES (EXPRESS OR IMPLIED) WITH REGARD TO THE PRODUCT. IN NO EVENT SHALL WHISPERKOOL BE LIABLE FOR INCIDENTAL, CONSEQUENTIAL, SPECIAL OR CONTINGENT DAMAGES FOR BREACH OF ANY EXPRESS OR IMPLIED WARRANTY ON THIS PRODUCT. THE IMPLIED WARRANTIES OF MERCHANTABILITY AND FITNESS FOR A PARTICULAR PURPOSE ARE HEREBY EXPRESSLY DISCLAIMED. Some states do not allow the exclusion or limitation of incidental or consequential damages, or allow limitations on how long an implied warranty lasts, so the above limitations or exclusions may not apply to you. This limited warranty gives you specific legal rights, and you may have other rights, which vary from state to state.
15. Failure of the End User to comply with all of the Product Installation Requirements, Maintenance Requirements and End User Requirements may, at WhisperKOOL's sole discretion, void this limited warranty.
16. No one has any authority to add to or vary the limited warranty on this Product.

3. Product Installation Requirements:

- A. Prior to installing a WhisperKOOL Product, the End User must read the WhisperKOOL Owner's Manual and thereafter the End User must follow the required installation, use and maintenance procedures set forth by WhisperKOOL in WhisperKOOL's Owner's Manual. The Owner's Manual is shipped with each Product and if another copy is needed, replacement copies can be downloaded from WhisperKOOL's website (www.whisperkool.com) or by contacting WhisperKOOL directly for a new copy of the Owner's Manual.
- B. It is highly recommended that the End User obtain the assistance of a wine storage professional.
- C. Failing to address all of the variables associated with proper installation will cause the Product to operate incorrectly and limit both the Product's ability to cool and the longevity of the Product itself.
- D. The End User is responsible for all risks and costs of installation of the Product, including but not limited to all labor costs as well as cost of any additional parts required for the proper and complete installation of the Product. The End User is responsible for all risks and costs of removing the Product if limited warranty work is required.
- E. The Product cannot operate at its optimum capacity if airflow is constricted by ducting or venting the exhaust side of the Product into a location with inadequate ventilation.

4. Maintenance Requirements

It is the End User's responsibility to clean off any accumulated dust, lint, or other debris from the front and rear intake grills. Failure to do this on a regular basis will restrict the airflow and may affect the Product's ability to function properly. Periodically cleaning the Product's vents will help assure maximum cooling efficiency. The drain line tube must also be checked and kept clean and free of debris and mold to maintain proper performance.

Mold is a natural living organism in the environment. It exists in the air in the form of microscopic spores that move in and out of buildings through doors, windows, vents, HVAC systems and anywhere else that air enters. Once it is discovered, mold must be addressed quickly and appropriately. Delayed or improper treatment of mold issues can result in costly and reoccurring repairs. If the End User suspects a mold problem, it is always best to hire a qualified and experienced mold remediation specialist.

5. Additional End User Costs And Responsibilities

The following items are not covered under any warranty and are the sole responsibility of the End User:

- A. End Users should satisfy themselves that the Product they are purchasing is suitable for their particular needs and requirements, and thus no responsibility will be placed with WhisperKOOL for the End User's decisions in this regard.
- B. It is the End User's responsibility to secure safe haven/storage for ANY AND ALL items that are being kept and stored in the End User's wine cellar, including any Product. WhisperKOOL takes no responsibility for the safety and preservation of the aforementioned items in the event that the environment becomes unsuitable to maintain a proper storage environment.
- C. End User is responsible for initial installation costs, including, but not limited to, labor costs and the cost of any additional parts necessary to complete the installation.
- D. End User is responsible for all costs incurred for the installation and/or removal of the Product, or any part thereof, unless such cost has been agreed by WhisperKOOL to be a warranty repair prior to the work being performed.

6. Sales and Use Tax

WhisperKOOL only collects California sales tax for orders shipped within the State of California. WhisperKOOL does not collect sales tax for orders shipped to other states. However, the Purchaser and the End User may be liable to the taxing authority in their state for sales tax and/or use tax on the Product. The Purchaser and the End User should each check with their state's taxing authority for sales and use tax regulations.

7. Customer Service and Troubleshooting

WhisperKOOL's Customer Service department is available to answer any questions or inquiries for End Users regarding a WhisperKOOL Product, as well as to assist in performing basic troubleshooting, Monday through Friday, from 6:00 a.m. to 4:00 p.m. (PST), at 1-800-343-9463. WhisperKOOL Corporation is located at 1738 East Alpine Avenue, Stockton, California 95205.

8. Miscellaneous Terms and Conditions

- A. Return Policy: All return inquiries must be made within thirty (30) calendar days of the original purchase of a Product and are subject to a twenty five percent (25%) restocking fee. Shipping costs are not refundable and the Purchaser is responsible for all return shipping costs (including customs fees and duties, if applicable).
- B. Security Interest: WhisperKOOL retains a security interest in each Product until payment in full.
- C. Construction and Severability: Every provision of these Terms and Conditions shall be construed, to the extent possible, so as to be valid and enforceable. If any provision of these Terms and Conditions is held by a court of competent jurisdiction to be invalid, illegal or otherwise unenforceable, such provision will, to the extent so held, be deemed severed from the contract of sale between Purchaser and WhisperKOOL, and all of the other non-severed provisions will remain in full force and effect.
- D. Governing Law/Choice of Forum: The laws of the State of California (without regard for conflicts of law) shall govern the construction and enforcement of the these Terms and Conditions of Sale (Sections 1 through 9 inclusive, including Product Limited Warranty And Product Installation Requirements), and further these Terms and Conditions of Sale shall be interpreted as though drafted jointly by WhisperKOOL and Purchaser. Any dispute will be resolved by the courts in and for the County of San Joaquin, State of California, and all parties, WhisperKOOL, Purchaser and End User, hereby irrevocably submit to the personal jurisdiction of such courts for that purpose. No waiver by WhisperKOOL of any breach or default of the contract of sale (including these Terms and Conditions of Sale) concerning a Product will be deemed to be a waiver of any preceding or subsequent breach or default.
- E. Correction of Errors and Inaccuracies: These Terms and Conditions may contain typographical errors or other errors or inaccuracies. WhisperKOOL reserves the right to correct any errors, inaccuracies or omissions, and to change or update these Terms and Conditions, at any time without prior notice.

9. Questions, Additional Information And Technical Assistance

A. Questions: If you have any questions regarding these Terms and Conditions or wish to obtain additional information, contact us via phone at 1-800-343-9463 or please send a letter via U.S. Mail to:

Customer Service
WhisperKOOL Corporation
1738 E Alpine Ave
Stockton, CA 95205

E-mail: support@whisperkool.com
Web: www.whisperkool.com

B. Technical Assistance: WhisperKOOL Customer Service is available Monday through Friday from 6:00 a.m. to 4:00 p.m. (PST). The Customer Service representative will be able to assist you with your questions and warranty information more effectively if you provide them with the following:

1. The model and serial number of your WhisperKOOL UNIT.
2. The location of the system and installation details, such as ventilation, construction of your wine cellar, and room size.

Model **EX** _____ Serial Number **A** _____

Installed by _____ Date _____

NOTES

NOTES

*Whisper***KOOL**[™]

WhisperKOOL
1738 E. Alpine Ave
Stockton, CA 95205
1-800-343-9463
www.whisperkool.com